

FC and FCA

Engine Start Battery Charger



Accurate, Completely Automatic Charging For All Types of Batteries

- **Automatic 2-rate charging** – offers fast charging and low water consumption
- **Temperature compensation** – eliminates the No. 1 cause of battery failure
- **Wide range of configurations** – 6 or 10A, with or without alarms
- **Current limited** – no crank disconnect required
- **Adapts to all types of batteries** – lead acid or nickel cadmium
- **Available alarm system** – meets NFPA 110 requirements



FC and FCA Charger Specifications

AC Input	120 VAC, 60 Hz standard. Optional 208 or 480 VAC, 60 Hz or 230 VAC, 50/60 Hz
Charger Output	12, 24 or 32-volt. 6 or 10-amp as shown on Ordering Information table, suited for either lead-acid or nickel cadmium battery types. Temperature compensated output with automatic 2-rate charge control. Voltage regulation $\pm 1\%$ of the correct temperature compensated value
Indication	Output ammeter and voltmeters, 2.5" scale, 5% accuracy. Model FCA adds LED status indicator for AC on, plus NFPA 110 compliant alarms for AC fail, low DC volts, high DC volts and charger fail. Alarm indication is by LED and Form C contact. Contacts rated 2A @ 26 VDC
Adjustments	Float and equalize voltages are separately adjustable
Protection	Electronic current limit (no crank disconnect required). Input and output fuses
Environmental	-10C to +50C operating temperature, 5% to 95% humidity, non-condensing
Mechanical/Construction	Wall mounting, clear anodized aluminum housing
Agency Compliance	See Ordering Information table. 12 and 24V chargers with 120 VAC input are listed to UL 1236 (required for UL 2200 gensets). Model FCA also complies with NFPA 110

Optional features

Non-standard input voltage
0-24 hour or 0-72-hour equalize timer
NEMA 3R housing

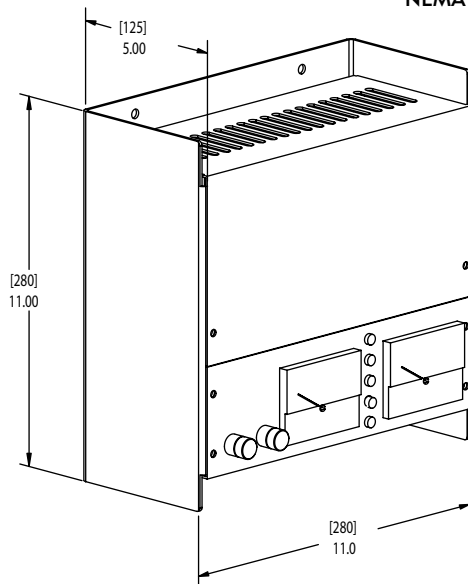

FC and FCA Ordering Information

Output Volts	Output Amps	Model ¹	AC Input ¹	NFPA 110 Alarms	Net Lbs	Weight Kg	Agency listing ²
12	6	FC12-6-2011U	120 VAC	No	15	7	UL listed
12	6	FCA12-6-2411U	120 VAC	Yes	15	7	UL listed
12	10	FC12-10-2011U	120 VAC	No	17	8	UL listed
12	10	FCA12-10-2411U	120 VAC	Yes	17	8	UL listed
24	6	FC24-6-2011U	120 VAC	No	24	11	UL listed
24	6	FCA24-6-2411U	120 VAC	Yes	24	11	UL listed
24	10	FC24-10-2011U	120 VAC	No	26	12	UL listed
24	10	FCA24-10-2411U	120 VAC	Yes	26	12	UL listed
32	10	FCA32-10-2411	120 VAC	Yes	28	13	

1. Model number shows standard 120 VAC unit only. Contact factory for model number of units with optional inputs or features
2. UL listing applies to 120 VAC units

Additional Information

Contact SENS or your local sales representative for additional specification, engineering and installation information. Check the SENS web site for latest available data. Specification is subject to change without notice.



Contact Information

For information and service on any SENS product, please contact us at:
Sales 1.866.736.7872 • 303.678.7500 • Fax 303.678.7504
www.sens-usa.com • info@sens-usa.com
1840 Industrial Circle, Longmont, CO 80501 USA

