

<b>Electrical Characteristics</b>											
Frequency	Hz	50				60					
Voltage (series star)	V	380	400	415	440	415	440	460	480		
Rated power class H	kVA	70	70	70	65	75	80	84	84		
	kW	56	56	56	52	60	64	67,2	67,2		
Rated power class F	kVA	63	63	63	52	68	75	78	78		
	kW	50,4	50,4	50,4	41,6	54,4	60	62,4	62,4		
Regulation with	SR7/2	±1,5 % with any power factor and speed variations between -5% +30%									
Insulation class		H									
Execution		Brushless									
Stator winding		12 ends									
Rotor		with damping cage									
Efficiencies class H	4/4	%	90,7	90,8	90,5	90,3	92,9	93,4	93,5	93,6	
(see graph. for details)	3/4	%	90,9	91,2	91,1	90,8	92,9	93,1	93,3	93,5	
	2/4	%	89,7	89,8	89,8	89,8	90,9	91	91,1	91,2	
	1/4	%	87,2	87	86,8	86,5	88,2	88,2	88,2	88	
Reactances (f. l.cl. F)	Xd	%	315,8	285	264,8	218,7	340,4	323,0	310,3	285	
	Xd'	%	13,85	12,5	11,61	9,59	14,93	14,17	13,61	12,5	
	Xd''	%	7,20	6,5	6,04	4,99	7,76	7,37	7,08	6,5	
	Xq	%	121,9	110	102,2	84,4	131,4	124,7	119,8	110	
	Xq'	%	121,9	110	102,2	84,4	131,4	124,7	119,8	110	
	Xq''	%	35,5	32	29,7	24,6	38,2	36,3	34,8	32	
	X <sub>2</sub>	%	24,16	21,8	20,25	16,73	26,04	24,71	23,74	21,8	
	X <sub>0</sub>	%	3,43	3,1	2,88	2,38	3,70	3,51	3,38	3,1	
Short Circuit Ratio	Kcc		0,49	0,58	0,65	1,20	0,37	0,41	0,49	0,58	
Time Constants	Td'	sec.	0,065								
	Td''	sec.	0,0135								
	Tdo'	sec.	1,30								
	Tα	sec.	0,027								
Short Circuit Current Capacity		%	>300				>350				
Excitation at no load	Amp.		0,5	0,6	0,7	1,2	0,25	0,3	0,4	0,5	
Excitation at full load	Amp.		2	2,1	2,3	2,7	1,7	1,6	1,8	2	
Overload (long-term)	%	1 hour in a 6 hours period 110% rated load									
Overload per 20 sec.	%	300									
Stator Winding Resistance (20°C)	Ω	0,035									
Rotor Winding Resistance (20°C)	Ω	3,171									
Exciter Resistance (20 °C)	Ω	Rotor : 0,442					Stator : 11,35				
Heat dissipation at f.l.cl.H	W	5742	5674	5878	5586	4586	4522	4672	4595		
Telephone Interference		FHT < 2%				TIF < 45					
Radio interference		EN50081-1, EN50082-1, VDE0875K. For others standards apply to factory									
Waveform Distors.(THD) at f. load	LL/LN %	3,9 / 3,7									
Waveform Distors.(THD) at no load	LL/LN %	3,3 / 3,1									
<b>Mechanical characteristics</b>											
Protection		IP 21 (other protection on request)									
DE bearing		6312-2RS									
NDE bearing		6309-2RS									
Weight of wound stator assembly	kg	110									
Weight of wound rotor assembly	kg	72									
Weight of complete generator	kg	298									
Maximun overspeed	rpm	2250									
Unbalanced magnetic pull at f.l.cl.F	kN/mm	5,2									
Cooling air requirement	m <sup>3</sup> /min	11,8				14,5					
Inertia Constant (H)	sec.	0,101				0,121					
Noise level at 1m/7m	dB(A)	75 / 60				79 / 64					

**50 Hz**

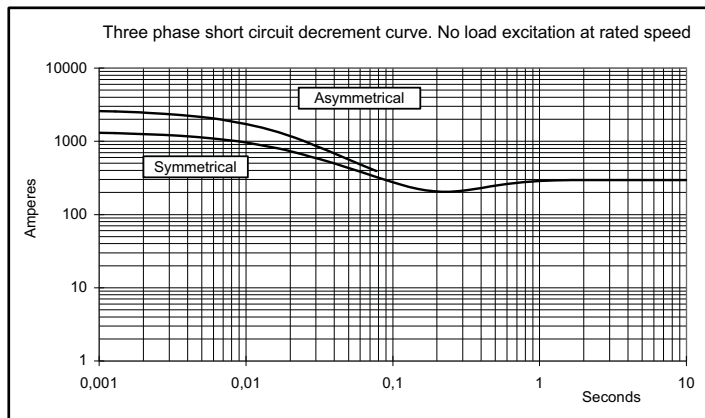

**60 Hz**

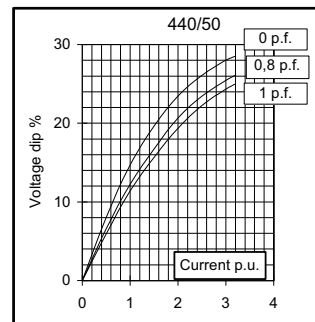
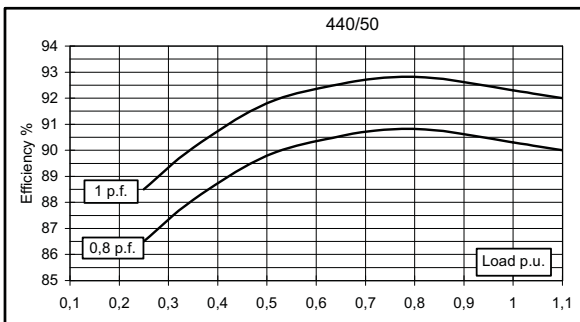
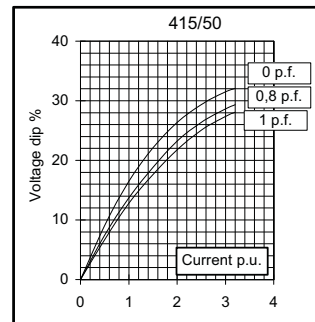
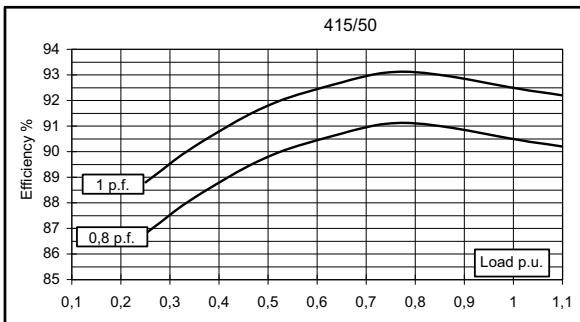
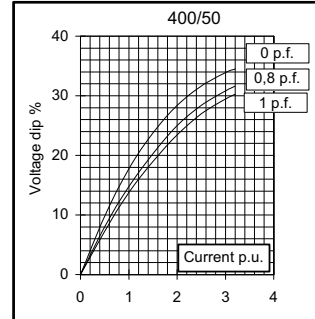
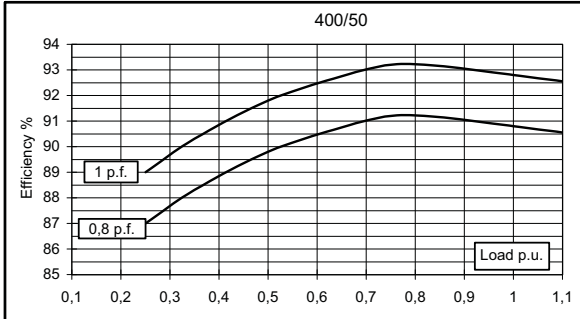
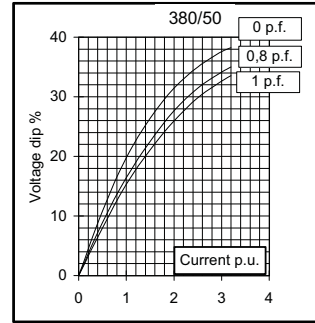
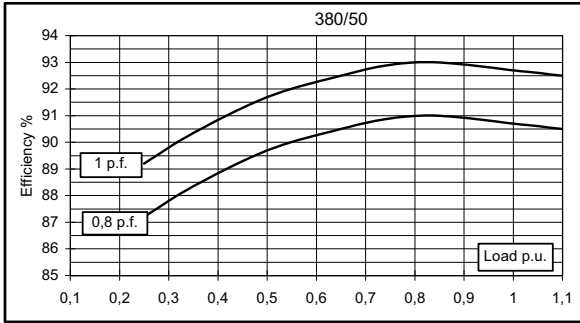
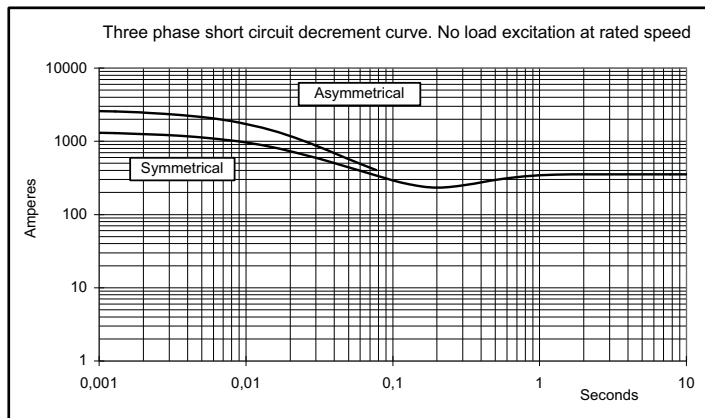
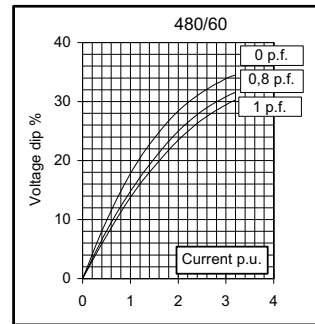
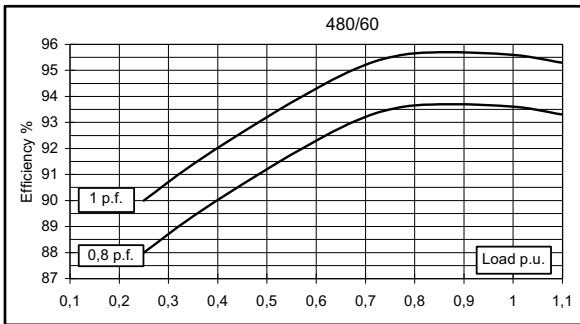
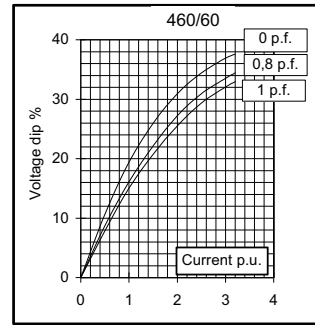
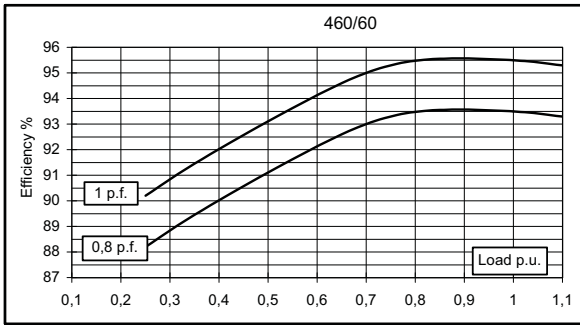
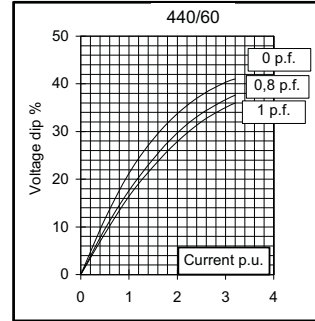
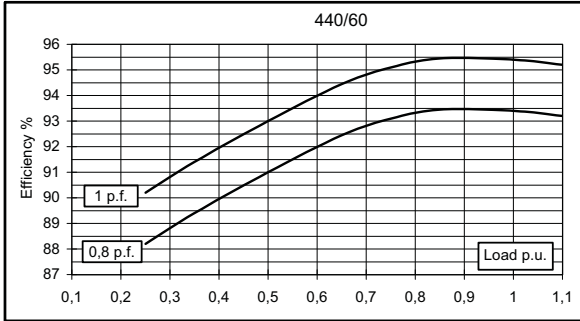
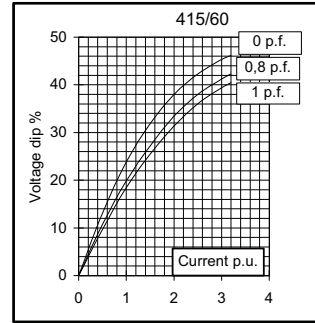
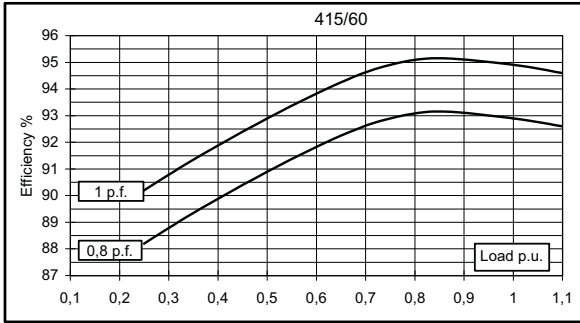



# SINGLE BEARING MOMENTS OF INERTIA

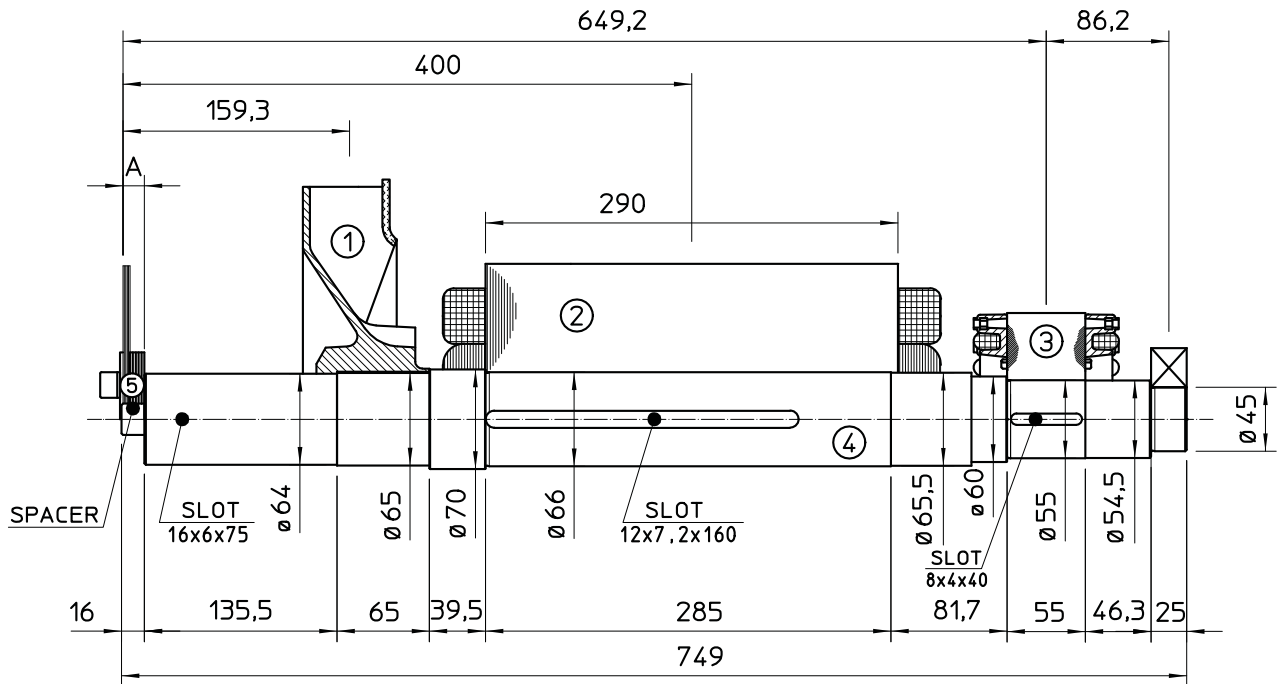

COMPONENT	WEIGHT kg	J kgm <sup>2</sup>
1 FAN	2,3	0,0224
2 MAIN ROTOR	74	0,5254
3 EX. ROTOR	7	0,016
4 SHAFT	18,3	0,0094
TOTAL	101,6	0,5732

SAE No	A (mm)	WEIGHT kg	J kgm <sup>2</sup>
5	5	1,74	0,0084
6,5	5	2,1	0,013
7,5	5	2,1	0,013
8	36,6	3,9	0,02
10	28,6	4,47	0,038
11,5	15	4,51	0,059

# SINGLE BEARING DIMENSIONS

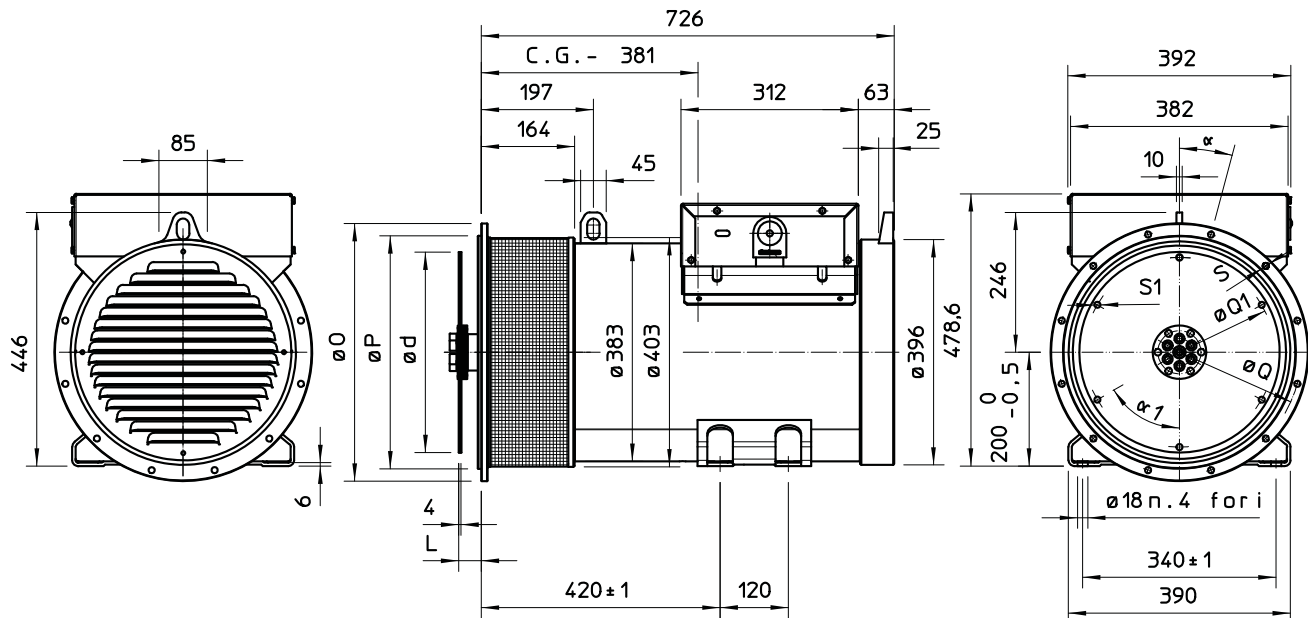

SAE No	DISC COUPLING					
	L	d	Q1	No holes	S1	α1
6,5	30,2	215,9	200	6	9	60°
7,5	30,2	241,3	222,25	8	9	45°
8	62	263,52	244,47	6	11	60°
10	53,8	314,32	295,27	8	11	45°
11,5	39,6	352,42	333,37	8	11	45°

SAE No	FLANGE					
	O	P	Q	No holes	S	α
5	356	314,3	333,4	8	11	22°30'
4	403	362	381	12	11	15°
3	451	409,6	428,6	12	11	15°
2	489	447,7	466,7	12	11	15°
1	552	511,2	530,2	12	11	15°

C.G. = GRAVITY CENTER