

Technical Data

1100D Series

1104D-44TG1

Electropak

Basic technical data

Number of cylinders... 4
 Cylinder arrangement... in-line
 Cycle... 4 stroke
 Induction system... turbocharged
 Combustion system... direct injection diesel
 Compression ratio... 18,2:1
 Bore... 105 mm
 Stroke... 127 mm
 Cubic capacity... 4,4 litres
 Direction of rotation... anticlockwise when viewed from flywheel
 Firing order (number 1 cylinder furthest from flywheel)... 1 3 4 2
 Estimated total weight of Electropak (dry)... 474 kg

Overall dimensions - Electropak

-height... 967 mm
 -length (air cleaner fitted)... 1238 mm
 -width... 637 mm

Moments of rotational inertia (mk²)

Engine rotational components... 0.132 kgm²
 Flywheel... 1.2 kgm²

Centre of gravity (fan face to flywheel housing)

Forward of rear face of cylinder block... 227,2 mm
 Above crankshaft centre line... 160,4 mm
 Offset to RHS of crankshaft centre line... 8,1 mm

Performance

Note: All data based on operation to ISO 3046-1:2002 standard reference conditions.

All ratings certified to within... ± 5%
 Speed variation at constant load... ± 0,25%
 Cyclic irregularity for 1,2kgm² flywheel inertia @ 1800 rev/min... 0,0118

Test conditions

-air temperature... 25 °C
 -barometric pressure... 100 kPa
 -relative humidity... 31.5%
 -air inlet restriction at maximum power (nominal)... 5 kPa
 -exhaust back pressure at maximum power (nominal)... 15 kPa
 -fuel temperature (inlet pump)... 40 °C

Sound level

Sound power level (exhaust piped away, cooling pack and air cleaner fitted)... 106,5 dB(A)

Note: Note: Sound power level calculated from the mean of 4 microphones sited, in front, right, left and above the engine (1m away)

If the engine is to operate in ambient conditions other than those of the test conditions, suitable adjustments must be made for these changes. For full details, contact Perkins Technical Service Department.

Emissions capability: Certified against the requirements of Tier 3 legislation for non-road mobile machinery, powered by constant

speed engines (EPA 40 CFR Part 89 Tier 3).

General installation

Designation	Units	Prime	Standby
Gross engine power	kWb	58,0	64,0
Electropak nett engine power	kWm	57,0	63,0
Brake mean effective pressure	kPa	879	971
Engine coolant flow (against 35 kPa restriction)	l/min	151	
Combustion air flow (at rated speed)	m ³ /min	5,2	5,3
Exhaust gas flow (Max.)	m ³ /min	12,8	13,7
Exhaust gas mass flow	kg/min	6,3	6,5
Exhaust gas temperature (turbocharger outlet)	°C	532	571
Boost pressure ratio		2,2	2,3
Overall thermal efficiency (nett)	%	35	33
Typical genset electrical output (0.8pf 25 °C)	kWe	51,3	56,7
	kVA	64,1	70,9
Assumed alternator efficiency	%	90	
Energy balance			
Energy in fuel	kWt	172,1	190,1
Energy in power output (gross)	kWb	58,0	64,0
Energy to cooling fan	kWm	1,0	
Energy in power output (net)	kWt	57,0	63,0
Energy to exhaust	kWt	59,3	66,9
Energy to coolant and lubricating oil	kWt	42,3	46,1
Energy to radiation	kWt	12,5	13,1

1104D-44TG1 - Left side view GAA0760

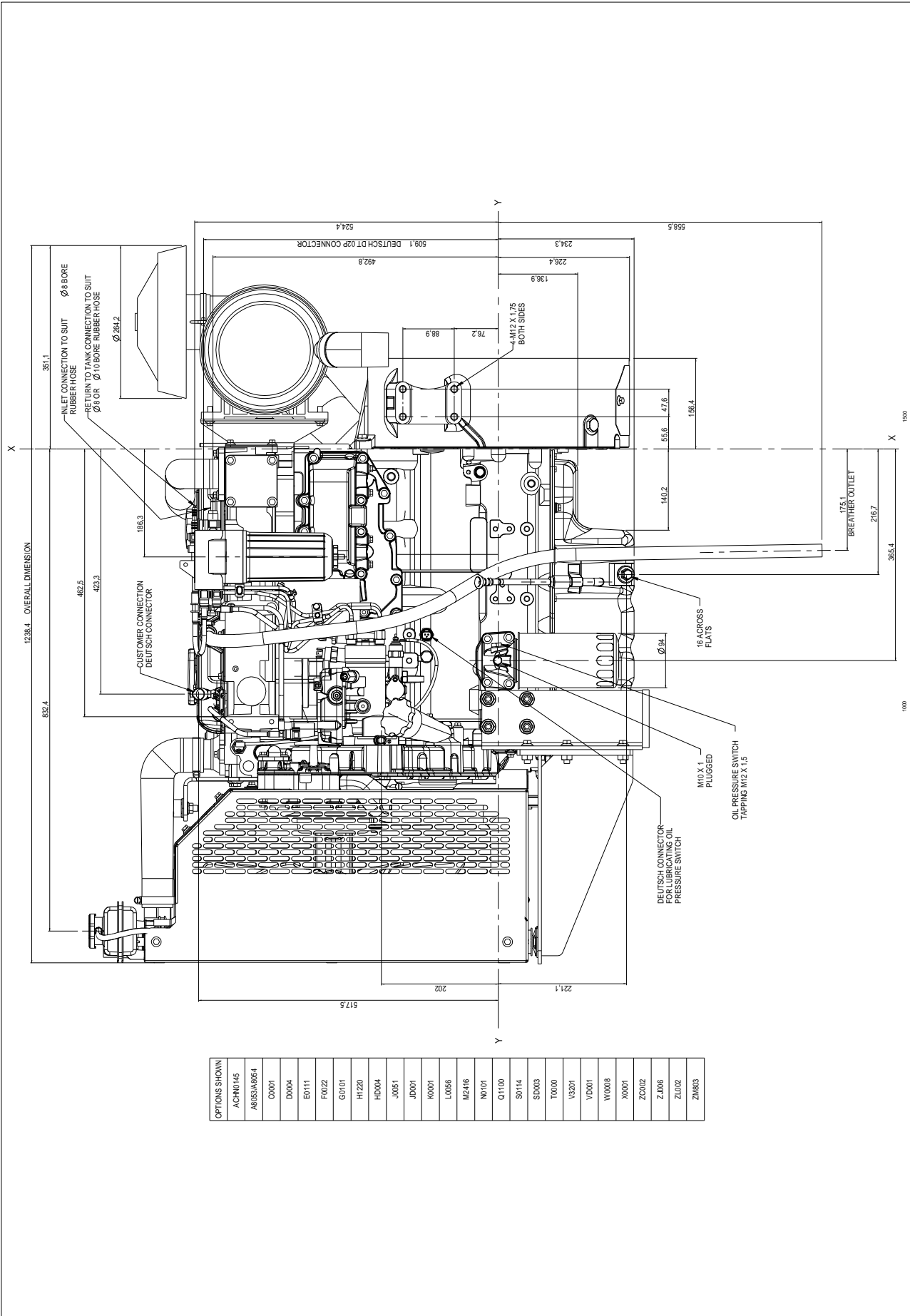

1104D-44TG1 - Front view GAA0760

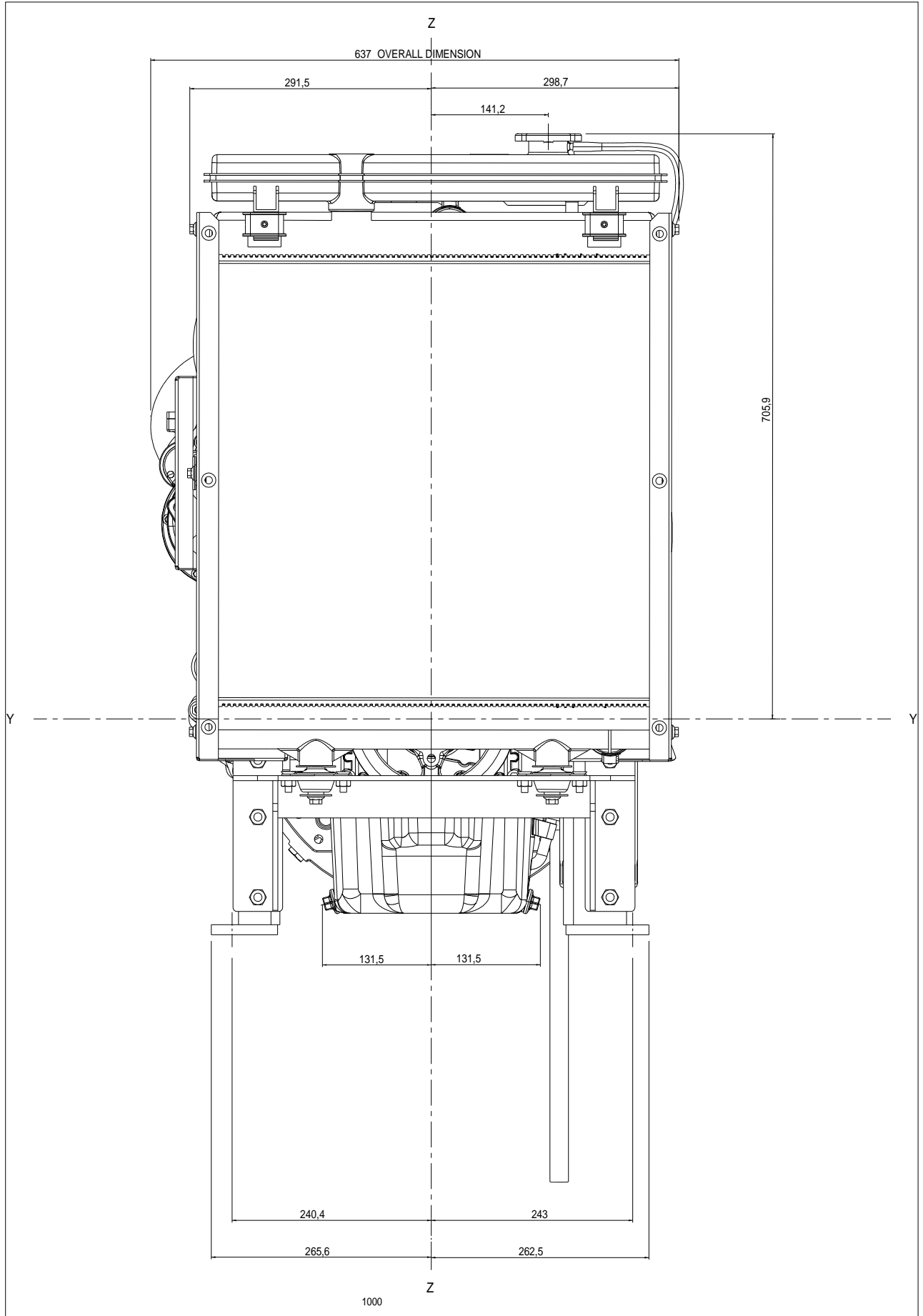

1104D-44TG1 - Right side view GAA0760

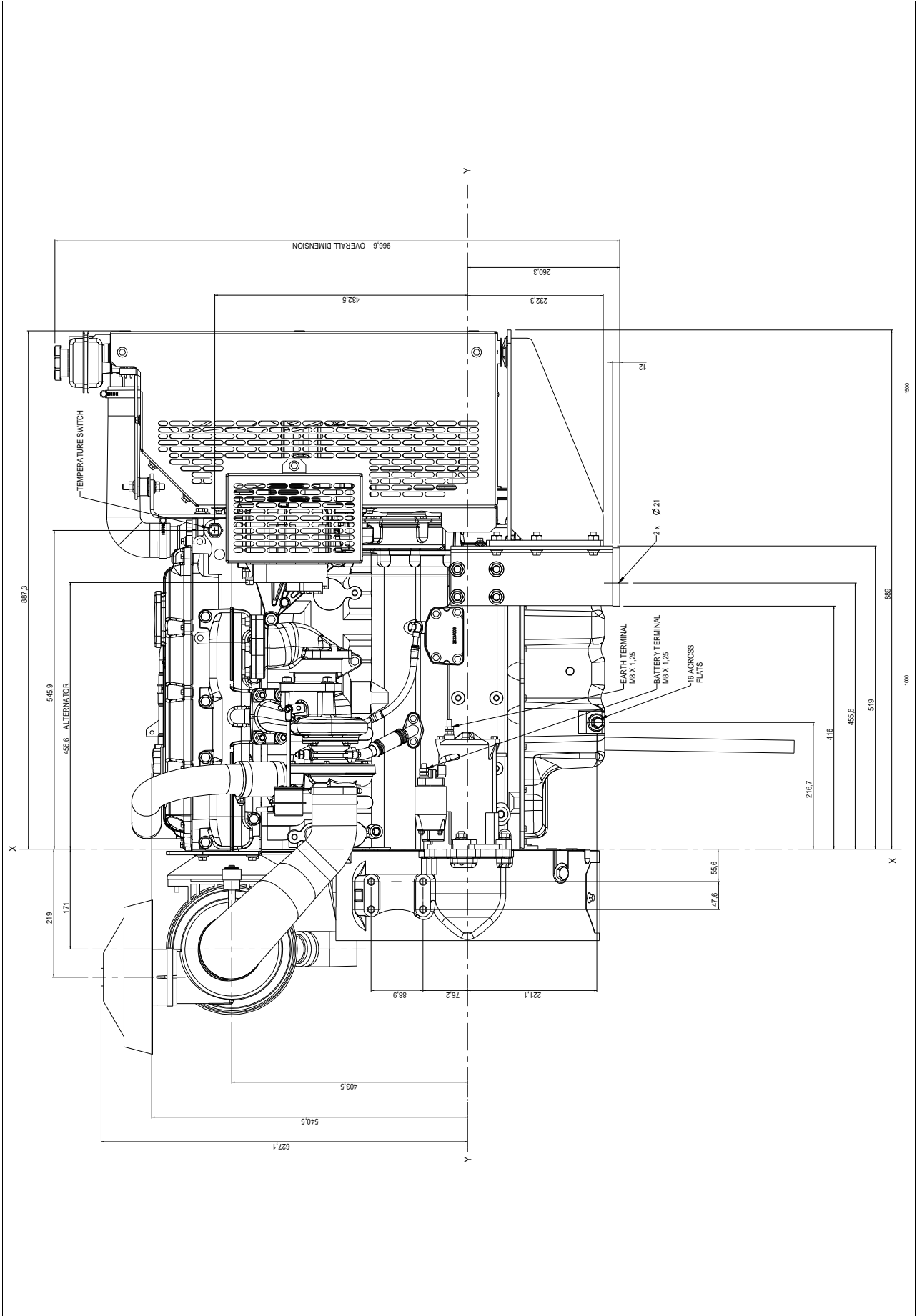

1104D-44TG1 - Rear view GAA0760

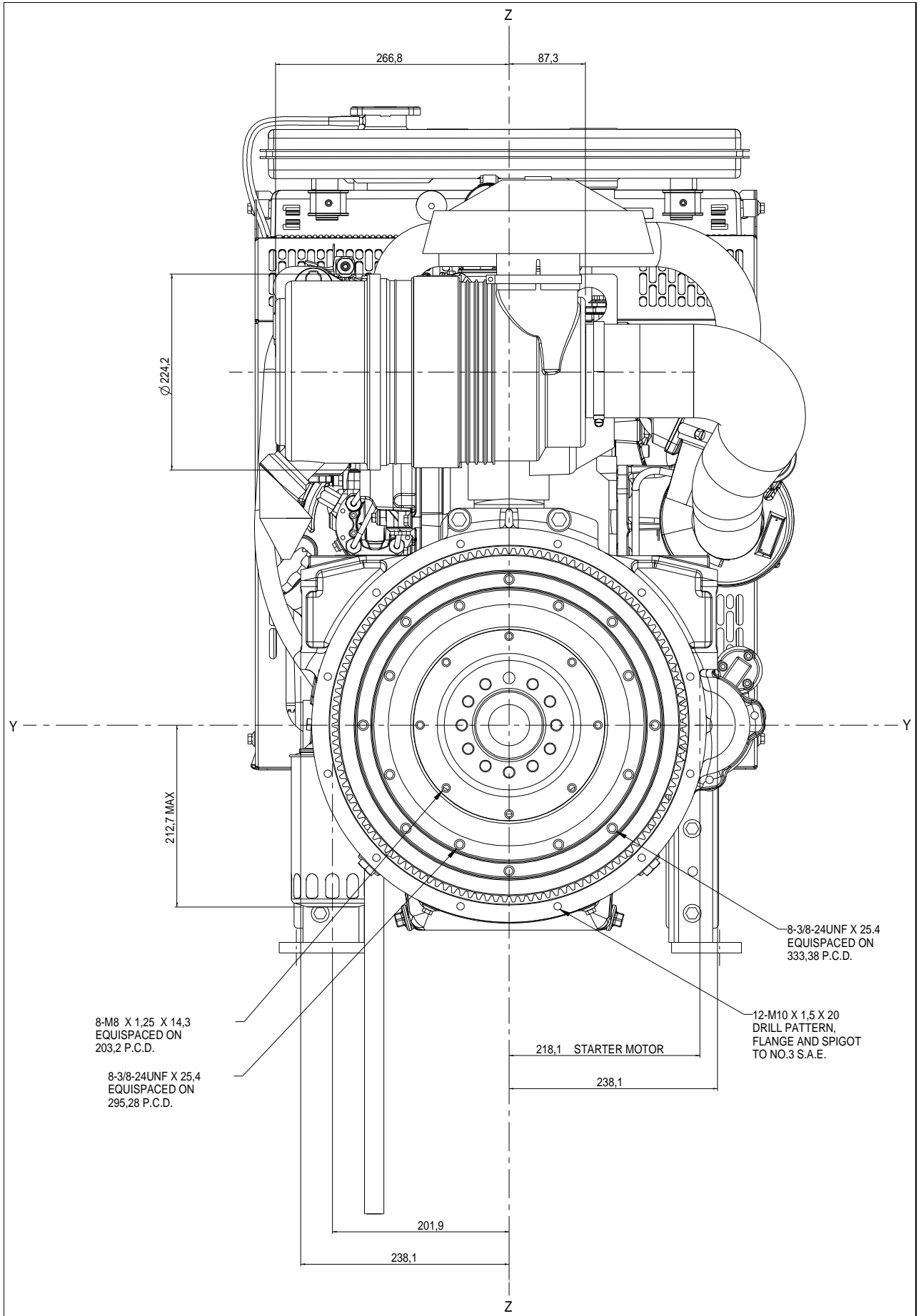

1104D-44TG1 - Plan view GAA0760

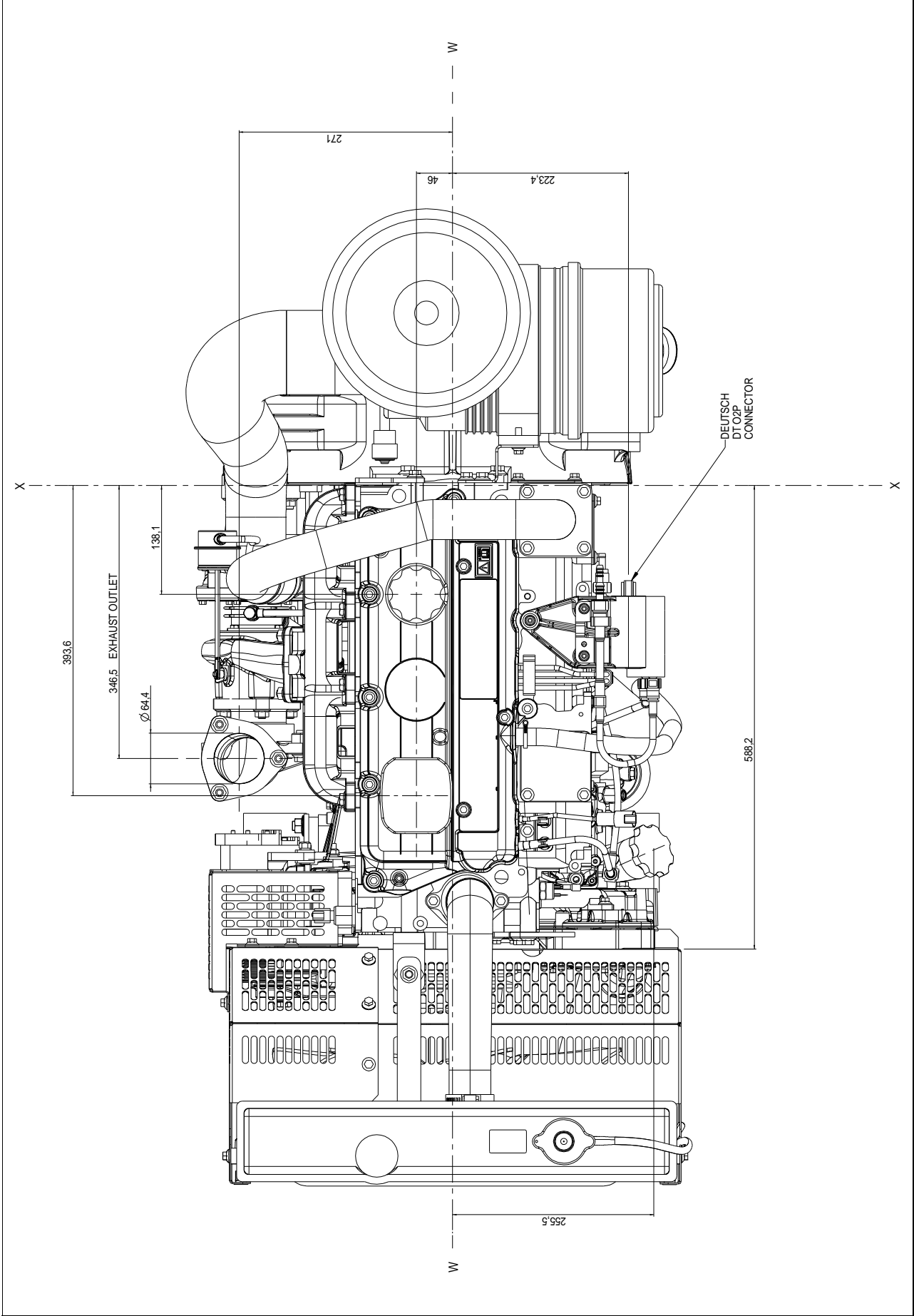

Cooling system

Cooling pack

-overall weight (wet) 71 kg
 -overall face area 275834 mm²
 -width 550 mm
 -height 762 mm

Radiator

Face area 275834 mm²
 Number of rows and materials 2 rows, aluminium
 Matrix density and material 12,7 fins per inch, aluminium
 Width of matrix 526,2 mm
 Height of matrix 524,2 mm
 Pressure cap setting (min) 100 kPa

Fan

Diameter 457,2 mm
 Drive ratio..... 1.25:1
 Number of blades..... 7
 Material composite
 Type..... pusher
 Cooling fan air flow @ 1800 rev/min 98,2 m³/min

Coolant

Total system capacity 16,5 litres
 Engine capacity 7,0 litres
 Maximum top tank temperature 112 °C
 Temperature rise across engine 6,6 - 7,0 °C
 Max. permissible external system resistance 35 kPa
 Thermostat operation range..... 85 to 95 °C
 Coolant pump drive type Gear driven
 Recommended coolant: 50% anti freeze / 50% water. For complete details of recommended coolant specifications, refer to the Operation and Maintenance Manual for this engine model

Duct allowance

Maximum additional restriction (duct allowance) to cooling airflow and resultant minimum airflow		
Ambient clearance 50% Glycol	Duct allowance Pa	m ³ /min
46°C	200	60
tba	tba	tba

Electrical system

-type 12 Volt negative earth
 Alternator type..... Denso A115i
 -alternator voltage 12V
 -alternator output..... 65 - 175A
 Starter motor type Iskra
 -starter motor voltage 12V
 -starter motor power AZE..... 3,2 kW
 -starter motor power AZF 4,0 kW
 Number of teeth on flywheel 126
 Number of teeth on starter pinion..... 10
 Minimum cranking speed 100 rev/min
 Starter solenoid maximum
 -pull-in current @ 0°C 62A
 -hold-in current @ 0°C 14A

Cold start recommendations

Minimum required cranking speed over TDC 100 rev/min

Cold start recommendation

Starter model	At Temp. °C	Oil viscosity limit	Minimum Battery CCA (cold cranking amps)	
			With glow plugs (SAE)	Without glow plugs
AZE ⁽¹⁾	-5	15W40	750	750
AZE ⁽¹⁾	-10	15W40	850	950
AZF ⁽²⁾	-15	15W40	1125	(3)
AZF ⁽²⁾	-20	10W40	1125	(3)
AZF ⁽²⁾	-25	5W30	1500	(3)

1. AZE starter - Battery must not exceed 950 CCA.
2. AZF starter - Battery must not exceed 2400 CCA.
3. Glow plugs must be used.

The table above shows the recommended battery sizes against starter model, temperature and oil viscosity and is based on the test results from starting a 'bare' engine with batteries at a 75% state of charge and with a cable resistance of 0,0017 Ohms.

Induction system

Maximum air intake restriction

-clean filter 5 kPa
 -dirty filter 8 kPa
 -air filter type..... paper element

Exhaust system

Maximum back pressure

-1800 rev/min 15.0 kPa
 Exhaust outlet, internal diameter 64 mm

Fuel system

Type of injection direct
 Fuel injection pump Delphi DP310
 Fuel atomiser..... unit injector / multi-hole
 Nozzle opening pressure 18,5 MPa
 Fuel filter particle size (maximum)..... 2 microns

Fuel lift pump

-max flow through customer filter 2,2 litres/min
 -max fuel supply restriction at lift pump 40 kPa
 -max fuel return restriction @ low idle 50 kPa
 -max fuel return flow 0,8 m³/min
 Maximum suction head 17 kPa (1.7 m)
 Maximum static pressure head 10 kPa (1.0 m)

Governor type

LCS electronic - speed control conforms to ISO 8528, G3
 Mechanical - speed control conforms to ISO 8528, G2

Fuel specification

Perkins recommend the use of the following fuel specifications:

- DIN E 590 DERV Grade A, B, C, E, F, Class 0, 1, 2, 3 & 4
- BS2869 Class A2 Off-highway Gas Oil Red Diesel
- ASTM D975, Class 1D and Class 2D
- JIS K2204 Grades 1, 2 & 3 & Special Grade 3

Note: For further information on fuel specifications and restrictions, refer to P.5 of the OMM Fuels section for this engine model

Fuel consumption

Load	rev/min g/kWhr	rev/min l/hr
Standby	243	18,7
Prime power	240	16,6
75% of Prime power	248	12,8
50% of Prime power	260	9,0
25% of Prime power	300	5,2

Note: Based on gross rated power.

Mountings

Flywheel housing ... SAE3 156,4mm
Maximum static bending moment at rear face of block... 1130 Nm

Lubrication system

Maximum total system oil capacity ... 8,4 litres
Minimum oil capacity in sump ... 5,6 litres
Maximum oil capacity in sump ... 6,9 litres
Maximum engine operating angles -
front up, front down, right side, left side . 24 °

Lubricating oil

-relief valve opens.. 450 kPa
-at maximum no-load speed .. 280 - 340 kPa
Oil temperature
-continuous operation ... 125 °C
-oil consumption at full load as a % of fuel consumption 0.15%

Recommended SAE viscosity

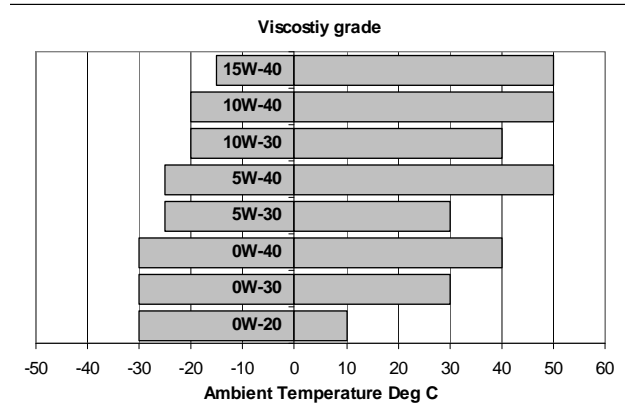

Load acceptance

The below complies with the requirements of classification 3 and 4 of ISO 8528-12 and G2 operating limits stated in ISO 8528-5

Initial load application: When engine reaches rated speed (15 seconds maximum after engine starts to crank)		
Descriptor	Units	60 Hz
% of prime power	%	80
Load (nett)	kWm (kWe)	45,6 (41,0)
Transient frequency deviation	%	3,8
Frequency recovery	Seconds	0,6

The above figures were obtained under the following test conditions:

- minimum engine block temperature ... 45 °C
- ambient temperature ... 15 °C
- governing mode ... isochronous
- alternator inertia ... 8kgm²
- under frequency roll off (UFRO) point set to ... 1 Hz below rated
- UFRO rate set to ... 2% voltage / 1% frequency
- LAM on/off ... off

All tests were conducted using an engine which was installed and serviced to Perkins Engines Company Limited recommendations.

Note: The general arrangement drawings shown in this data sheet are for guidance only. For installation purposes, latest versions should be requested from the Applications Dept., Perkins Engines Stafford, ST16 3UB United Kingdom.



Distributed by

Hardy Diesels & Equipment Inc
15749 Lyons Valley Rd.
Jamul, CA 91935
800-341-7027
HardyDiesel.com

