

PANCAKE GENERATOR

Installation, Operation, and Maintenance Manual



MARATHON ELECTRIC

GENERATORS

A REGAL-BELOIT COMPANY

TABLE OF CONTENTS

INTRODUCTION	2
SAFETY	2
INSTALLATION	2
Location/Environment	2
Mounting	3
CONNECTION DIAGRAMS	4
OPERATION	7
Initial Pre-Start Inspection	7
Initial Start-Up	7
Shut Down Procedures	8
MAINTENANCE	8
Routine Maintenance	8
Drying Generator Windings	8
SERVICE	8
General	8
Restoring Residual Magnetism (Flashing the Exciter Field)	9
Testing the Rotating Rectifier Assembly	9
SPARE PARTS	9
RETURNED GOODS	9
TROUBLESHOOTING PROCEDURES	9
WARNINGS AND CAUTIONS	Inside Back Cover

INTRODUCTION

Thank you for choosing a MARATHON ELECTRIC PANCAKE Generator. Please read the installation and service sections of this manual carefully. A clean environment and proper installation are critical to generator performance. If you have any difficulty in installing or servicing your Marathon Generator, our service and technical staff will be happy to help you. We are confident that by following these guidelines, you will get many years of reliable service from your Marathon generator.

General Data

Construction:	Brushless, Revolving Field
Number of Poles:	4
Frequency:	Frequency is model specific. Consult the generator name plate or the factory for your generator's designed frequency.
Synchronous Speeds:	60 Hz – 1800 rpm or 50 Hz – 1500 rpm
Cooling:	Fan cooled
Enclosure:	IP22
Max. Ambient Temp:	40°C
Insulation Class:	(See generator nameplate)

Initial Inspection

Your Marathon Pancake generator has been carefully inspected and tested before leaving the factory. However, it is wise to examine the generator before installation. Carefully unpack and examine the unit. If there is any shipping damage, file a damage claim with the shipper or agent immediately. Save all packing materials for inspection by agent.

SAFETY

PLEASE REMEMBER SAFETY FIRST. If you are unsure of the instructions or procedures contained in this manual, seek qualified help before continuing. **WHEN IN DOUBT, ASK.**

This manual emphasizes the safety precautions necessary during the installation, operation, and maintenance of your Pancake generator. Each section has caution and warning messages. These messages are for your safety and the safety of the equipment involved. If any of the cautions or warnings are not readily understood, seek clarification from qualified personnel before proceeding.

WARNING

Before any service work is done, disconnect all external power sources and, where appropriate, lock out all controls to prevent an unexpected start-up of the generator set driver. Proper grounding (earthing) in compliance with local and national electrical codes and standards must be provided. These safety precautions are necessary to prevent potential serious personal injury or even death.

The hazards associated with lifting or moving your generator are pointed out in the installation and service sections. Incorrect lifting or moving can result in personal injury or damage to the unit. Prior to start-up of the unit,

insure that all generator leads are properly connected and insulated.

WARNING

Always assume that there will be voltage present at the generator terminals whenever the generator's shaft is rotating, and proceed accordingly. Residual voltage is present at the generator terminals, and at the automatic voltage regulator panel connections, even with the regulator fuse removed. Caution must be exercised, or serious injury or death can result.

This manual is not intended to be a substitute for properly trained personnel. Installation and repairs should only be conducted by qualified, trained people. The cautions and warnings point out known conditions and situations that are potentially hazardous. Each installation may well create its own set of hazards. No manual can cover every possible situation.

INSTALLATION

Location/Environment

The engine-generator set must be installed in a protected environment with minimal exposure to fumes, moisture, dust, and dirt. **THE AMBIENT AIR TEMPERATURE MUST NOT EXCEED 40°C (104°F) FOR CONTINUOUS DUTY WITHOUT A RECOMMENDED REDUCTION IN RATING.**

- a. **CAUTION**
DO NOT obstruct the generator intake and outlet air passages.
- b. Provide sufficient air circulation around the set to remove engine heat and to provide ample generator cooling.
- c. Hot air from the radiator or engine should not pass through the generator.
- d. Check the mounting surface to be sure that it is rigid enough to keep vibration and noise to a minimum.
- d. Detach main rotor leads from the red and black threaded studs on rectifier assembly (See Figure 2 on page 9).
- e. Remove exciter armature (rotor) mounting bolt from center of shaft, marking position of the rotor to aid in re-assembly.
- f. Remove exciter rotor from the shaft.
CAUTION
Take care not to damage the laminations or coil end turns.
- g. Remove exhaust screen band.
- h. Place a strap around generator rotor assembly and support from hoist.
- i. With the exciter armature removed, pull the rotor assembly from the frame.
CAUTION
Do not scratch or cut the copper stator windings.
- k. Insure that the flex discs are flush (flat) against the register of the flywheel. Bolt drive disk to engine flywheel, using proper sized flat washers and SAE grade 8 bolts. Consult engine manufacturer for proper torque value.
- l. Push generator frame assembly carefully back over rotor.
- m. Mount frame assembly to engine flywheel housing with proper size bolts, lock washers, and nuts.

Mounting

Mount the generator to the driver securely. Before tightening hold-down bolts, use shims as necessary under generator feet for uniform support. If this is not done, the frame may become distorted resulting in excess vibration that could damage the generator.

Assembly of a Single Bearing Generator to an Engine
To mount a single bearing generator to an engine (See Figure 1 for component identification):

- a. If the engine is equipped with electric start, disconnect the positive (+) terminal from battery.
- b. Place a jack or other support under the engine flywheel housing.
- c. Remove the pot cover or control box cover from back of generator and disconnect all incoming power leads.

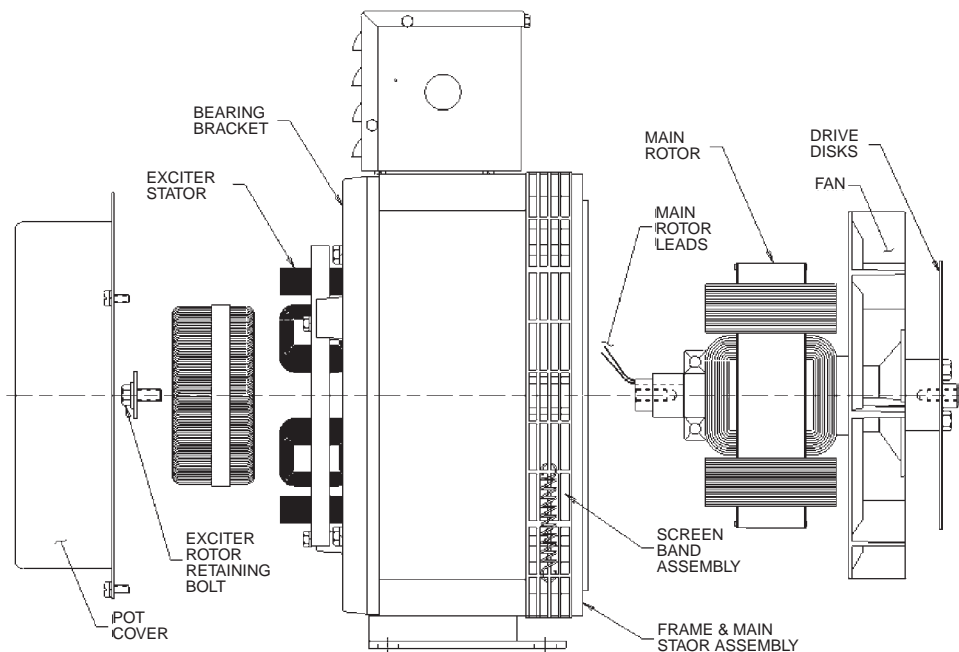

Figure 1- General Arrangement

- n. Remount exhaust screen band.
- o. To reassemble the armature, pull main rotor leads through the holes in the exciter rotor.
CAUTION
DO NOT PINCH ROTOR LEADS.
- p. Replace the mounting bolt, lock washer, and Belleville washer. Using a 9/16" socket on a torque wrench, torque the mounting bolt to 30 to 35 ft-lb.
- q. Reconnect main rotor leads to proper connections.
- r. Reconnect all incoming power leads as shown on wiring diagram.
- s. Replace pot cover or control box cover.
- t. Remove jack support from under engine flywheel housing.
- u. See preceding paragraph "a." If necessary, reconnect positive (+) lead to the engine cranking battery.

ELECTRICAL CONNECTIONS

NOTE: INSURE THAT ALL ELECTRICAL CONNECTIONS ARE CORRECT BEFORE STARTING GENERATOR. REFER TO THE AUTOMATIC VOLTAGE REGULATOR (AVR) MANUAL FOR SPECIFIC INSTRUCTIONS FOR CONNECTING THE AVR.

Dedicated 4 lead single phase generator connections.

SINGLE PHASE CONNECTION - DUAL VOLTAGE SERIES			
	VOLTAGE		
		L-L	L-N
	60 HZ	240	120
	50 HZ	220	110

SINGLE PHASE CONNECTION - SINGLE VOLTAGE PARALLEL		
	VOLTAGE	
		L-L
	60 HZ	120
	50 HZ	110

Three phase, 12 lead generator connections.

Note: 12 lead Pancake generators are not broad range voltage machines. The voltages available in a given three phase connection are model specific. Refer to the generator nameplate, or the factory, with the generator model number, for the voltage available from your unit in any of the below listed connections.

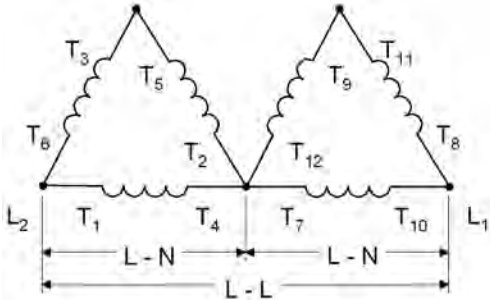
DOUBLE DELTA-SINGLE PHASE CONNECTION			
	VOLTAGE		
		L-L	L-N
	60 HZ	240	120

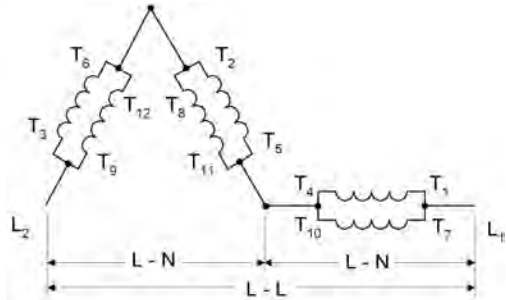
LOW ZIG ZAG-SINGLE PHASE CONNECTION			
	VOLTAGE		
		L-L	L-N
	60 HZ	240	120

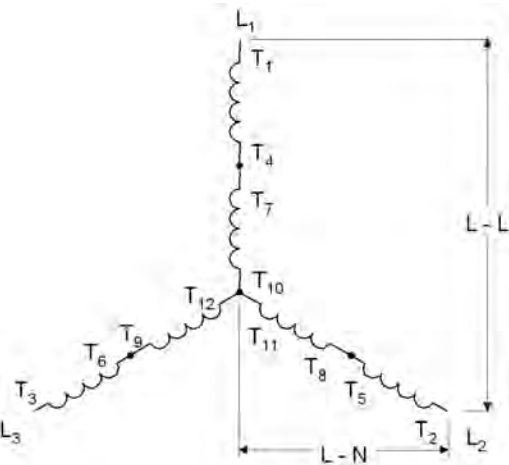
12 LEAD HIGH VOLTAGE (SERIES) WYE (STAR) CONNECTION			
	VOLTAGE		
		L-L	L-N
	60 HZ	480	277
		460	266
		440	254
416		240	

12 LEAD HIGH VOLTAGE (PARALLEL) WYE (STAR) CONNECTION

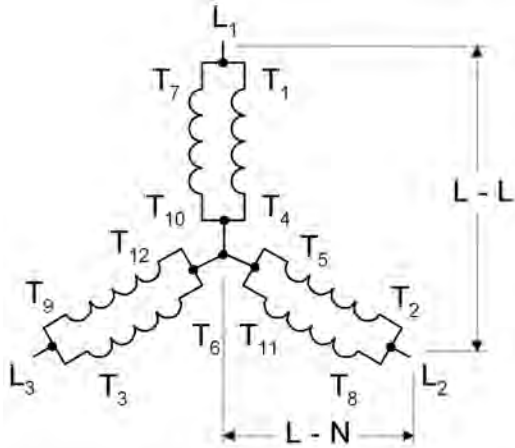

VOLTAGE

	L-L	L-N
60 HZ	240 230 220 208	139 120 127 120

12 LEAD HIGH VOLTAGE (SERIES) DELTA CONNECTION

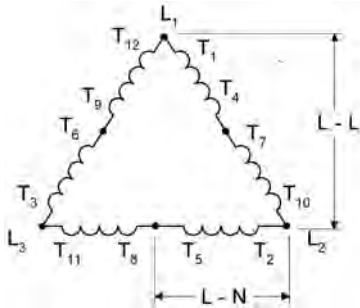

VOLTAGE

	L-L	L-N
60 HZ	240	120

12 LEAD HIGH VOLTAGE (PARALLEL) DELTA CONNECTION

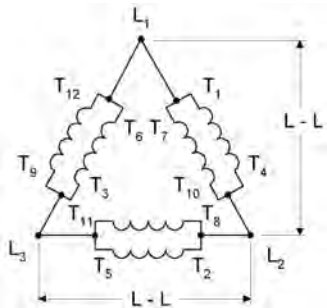

VOLTAGE

	L-L	L-N
60 HZ	120	N.A.

OPERATION

Initial Pre-Start Inspection

Before starting the unit for the first time, the following inspections and checks are recommended:

- a. Clear the site area of any loose parts, connections, or foreign materials such as cut off tie wrap ends, scrap insulating tape, tools, hardware, etc.
- b. Insure that the set turns freely. Bar the set over by hand for at least 2 revolutions to be sure that there is no interference. Do not use the generator's fan as a fulcrum to bar over the set. If the generator rotor seems to bind, check for clearance in the generator and exciter air gap.
- c. Check all wiring against the proper connection diagrams, and insure that all connections and terminations are tight and properly insulated.

⚠ WARNING

PANCAKE GENERATORS MAY HAVE VOLTAGE PRESENT AT THEIR LEAD TERMINALS WHEN THE SHAFT IS ROTATING. DO NOT PERMIT OPERATION OF THE UNIT UNTIL ALL LEADS HAVE BEEN CONNECTED AND INSULATED. FAILURE TO DO THIS MAY RESULT IN PERSONAL INJURY OR EQUIPMENT DAMAGE.

- d. Insure that all equipment is properly grounded (earthed).
- e. Inspect for any remaining packing materials, and remove any loose debris, building materials, rags, etc., which could be drawn into the generator.
- f. Check all fasteners for tightness.
- g. Check all access plates, covers, screens, and guards. If they have been removed for assembly or inspection, reinstall and check for security.
- h. Review all prime mover manufacturer's pre start-up instructions, and insure that all recommended steps and procedures have been followed.
- i. Remove any paint masking material from the generator nameplate and warning/caution decals.

Initial Start-Up

The following procedure should be followed for starting-up the generator set for the first time:

- a. The generator output must be disconnected from the load. Be sure that the main circuit breaker or fused

disconnect is in the open position.

- b. Open the input power to the automatic voltage regulator (AVR). Remove the fuse or disconnect and insulate one of the AVR input power leads (see AVR manual).
- c. Insure that all prime mover manufacturer's pre-start-up and start-up procedures have been followed.
- d. Start the prime mover, and adjust it for proper speed (frequency). (See generator nameplate.)
- e. The purpose of this initial test with the AVR out of the circuit is to detect any wiring mistakes without exposing the unit to undue risk. Check all Line-to-Line and Line-to-Neutral voltages for balanced voltage. At this point, with the AVR de-energized, the residual voltage should be about 10% to 25% of rated value. If voltages are unbalanced, shut down the equipment and check for improper wiring. Re-start the set, and again check for voltage balance. If the problem persists, consult the factory. If everything checks good, shut down the set and reconnect the AVR. It is recommended that the residual voltage, together with driver rpm, be recorded for use as a future troubleshooting benchmark.
- f. Start the set and adjust the terminal voltage to the desired value by means of the AVR voltage adjustment device. If the AVR is equipped with a stability adjust, follow the instructions in the AVR manual to adjust the stability. Again, check all line-to-line and line-to-neutral voltages for balance. It is recommended practice to record the no load excitation (DC voltage across F+ and F-) together with line-to-line voltage and driver rpm as a benchmark for future troubleshooting.

⚠ WARNING

THIS PROCEDURE MUST BE CONDUCTED BY QUALIFIED ELECTRICAL PERSONNEL. LETHAL VOLTAGE MAY WELL BE PRESENT AT BOTH. THE GENERATOR AND VOLTAGE REGULATOR TERMINALS DURING THIS PROCEDURE. CAUTION MUST BE EXERCISED NOT TO COME INTO PERSONAL CONTACT WITH LIVE TERMINALS, LINKS, OR STUDS. SERIOUS INJURY OR DEATH COULD RESULT.

- g. Close the main circuit breaker to the load. If the unit is equipped with space heaters, insure that they are turned off.
- h. Monitor the generator output current to verify that it is at or below nameplate value.

- i. Check generator frequency (speed) under load. Adjust as necessary. (Refer to prime mover/governor manuals)

Shut down procedures.

There are no specific instructions for shut down of the generator; however, several good engineering practices should be observed to prolong equipment life.

- a. It is advisable to disconnect all loads (open main circuit breaker or disconnect) prior to shut down. This is especially important if loads can be damaged by low voltage and/or frequency conditions during generator “coast down”.
- b. Isolate any condition that could allow the generator to see a voltage at its terminals while at rest. Failure to do this could result in personnel injury or equipment damage.

MAINTENANCE

Routine Maintenance

Your Marathon Pancake generator has been designed to be as reliable and trouble free as is possible. However, costly repairs and down time can be minimized by operating the unit under conditions that are compatible with those at which the equipment was designed to operate (See OPERATION section). The following maintenance procedures should be followed to insure long equipment life and satisfactory performance.

- a. Routinely check intake and exhaust air screens to insure that they are clean and free of debris. Clogged intake air screens will reduce cooling airflow and may result in the unit operating at dangerously high temperatures which reduce the generator's life. This inspection and cleaning should be done in conjunction with prime mover air filter cleaning and/or change-out.
- b. Periodically (approximately every one thousand [1000] operating hours) check the bearing(s). Pancake generators are equipped with prelubricated-for-life bearings which do not require routine lubrication.
- c. Periodically inspect the unit for buildup of contamination (dirt, oil, etc.) on the windings. If the wound components have become coated with heavy concentrations of oil and grime, the unit should be disassembled and thoroughly cleaned. This operation is not one that can be accomplished effectively on site, but rather one that should be conducted by an authorized service center equipped with the appropriate apparatus and solvents necessary to properly clean and dry the generator.

- d. Periodically, about once every 2000 operating hours, or in conjunction with scheduled engine maintenance, check the DC no load excitation voltage. Compare this voltage with the value recorded during initial startup. If this value of no load excitation voltage is markedly higher than the benchmark reading, it is an indication of problems in either the exciter field, main field, or possibly the rotating rectifier assembly. Insure that voltage and rpm is the same as initial test condition

Drying Generator Windings

Generators in service may inadvertently have their windings exposed to splashing or sprayed water. Units that have been in transit or storage for long periods of time may be subjected to extreme temperature and moisture changes causing excessive condensation. Regardless of the source of moisture, wet windings should be thoroughly dried out before operating the unit. If this precaution is not taken, serious damage to the generator can result. The following procedures may be used to effectively dry the unit's windings:

- a. Electric space heaters can be installed inside the generator frame. When energized from a power source other than the generator itself, they will heat and dry the inside of the generator. If an alternate source of electricity is not available, enclose the unit with a covering, and insert heating units to raise the machine's temperature 15°F to 18°F (8°C to 10°C) above the outside temperature. Leave a hole at the top of the enclosure to permit the escape of moisture.
- b. If the windings are damp, but not saturated, run the set for approximately 1 to 2 hours with excitation off (AVR power supply open). If the windings have been saturated, a portable air heater can be used by directing heat into the air intake openings, and running the set with no load and the excitation off for several hours. Heat at point of entry should not exceed 150°F (66°C).

SERVICE

General

The service procedures given in this section are those which can reasonably be conducted on-site with a minimum of special tools and equipment. All service procedures should be conducted by qualified maintenance personnel.

Restoring Residual Magnetism (Flashing the Exciter Field)

To restore the small amount of residual magnetism necessary to begin voltage buildup, connect a 12-volt battery to the exciter field while the generator set is at rest as follows:

- a. Remove exciter field leads F+ and F- from the AVR.



Failure to remove the exciter field leads from the automatic voltage regulator during flashing procedures may destroy the regulator.

- b. Connect exciter field lead F+ to the positive pole of the battery. Holding the F- lead by the insulated portion of the lead wire, touch exciter field lead F- to the negative pole of the battery for about 3 to 5 seconds. Remove the lead. You should see an inductive arc. If no arc is drawn when removing the F- lead, repeat the procedure.
- c. Reconnect F+ and F- to the AVR, re-start the unit, and observe voltage build-up. Repeat the procedure if build-up fails to develop.

the diodes contains three “Reverse” stud type diodes.

The diodes may be tested in the field without removing them from the heat sinks. Electrically isolate the individual diodes by removing each of exciter rotor lead flag terminals from the quick connect diode terminals, and remove the two main rotor leads from the main rotor terminal posts. Test each sub-assembly separately. An ohmmeter or a battery light continuity tester may be used to find an open or shorted condition in the diode. Place one tester probe on the main post. In succession, touch the other test probe to each diode terminal. Reverse the probes and repeat the procedure. You have now tested the three diodes on this sub-assembly. Repeat the test on the second sub-assembly. These tests should indicate one of three conditions:

- a. Good diode: Will have a much greater resistance in one direction than the other. Typical reverse resistance will be 30,000 - 300,000 ohms or greater, while typical forward resistance will be less than 10 ohms. The battery-light tester will have the light “on” in one direction, and “off” in the other.
- b. Shorted condition: Ohmmeter reading will be zero or very low in both directions. The continuity tester will have the light “on” in both directions.

- c. Open condition: Ohmmeter will have a maximum (infinity) reading in both directions. Continuity tester light will be dark (off) in both directions.

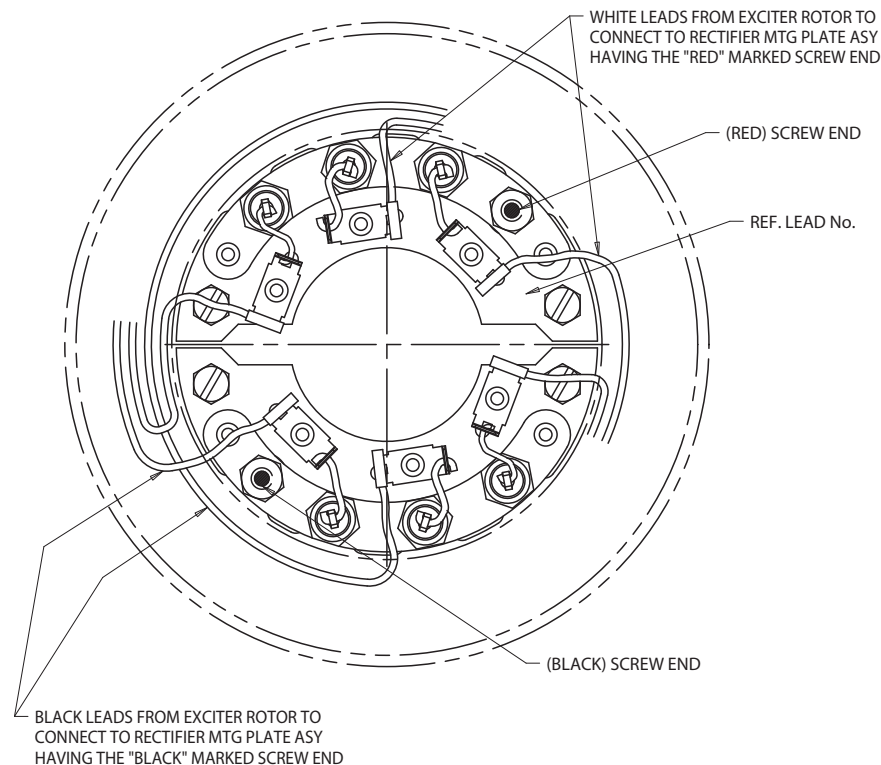

Figure 2 - Rotating Rectifier Assembly

Testing the Rotating Rectifier Assembly

The complete assembly consists of two semi-circular sub-assemblies (see Figure 2). The half assembly having white leads on the diodes contains three “Forward” stud type diodes, and the half assembly having black leads on

Diode failure after approximately a 25 hour “run-in” period is generally traceable to external causes such as lightning strike, over heating, reverse current fed into the unit, line voltage spikes, etc.. All 6 diodes are essentially in the same circuit. When one or more diodes have been stressed to failure, there is no easy method to determine how badly stressed the remaining diodes may have been. Therefore, to avoid possible continued failures and increased down time, it is recommended practice to replace the entire assembly rather than to replace only the individual failed diodes. If the rectifier assembly is to be repaired, the assembly must be removed from the unit.

SPARE PARTS

Always include the name of the part, the quantity of each part ordered, and the serial and model numbers from the generator nameplate when ordering parts. For ordering information, contact:

Marathon Electric Manufacturing Corporation
100 E. Randolph St
P.O. Box 8003
Wausau, WI 54402-8003
Phone: 715.675.8257 (or) 800.477.6362, ext. 8257

RETURNED GOODS

Consult Marathon Electric Manufacturing Corporation at the address above for authorization prior to returning any product. We cannot be responsible for any items returned without authorization.

⚠ CAUTION

Single bearing generators must have their rotor assembly properly secured to prevent damage during transit to the factory or to an authorized service center.

TROUBLESHOOTING PROCEDURES

General

This section is intended to suggest a systematic approach to locating and correcting generator malfunctions. The section is arranged according to the symptoms of the problem. The steps have been arranged in an attempt to (1); do the easy checks first, and (2); prevent further damage when troubleshooting a disabled machine.

⚠ WARNING

HIGH VOLTAGES MAY BE PRESENT AT THE GENERATOR TERMINALS WHEN THE UNIT IS RUNNING. TOOLS, CLOTHING, AND YOUR BODY MUST BE KEPT CLEAR OF ROTATING PARTS AND ELECTRICAL CONNECTION.

SPECIAL PRECAUTION MUST BE TAKEN DURING TROUBLESHOOTING SINCE PROTECTIVE COVERS AND SAFETY DEVICES MAY BE REMOVED OR DISABLED TO GAIN ACCESS AND MAKE TESTS. BE CAREFUL. SERIOUS PERSONAL INJURY OR DEATH CAN RESULT FROM THESE HAZARDS! CONSULT QUALIFIED PERSONNEL WITH ANY QUESTIONS.

Speed Deviations

The generator speed should be maintained at rated nameplate value during all operating tests. The frequency of the generator depends upon rotative speed. Most AVR's used with our Pancake generators have built in underfrequency protection such that if the speed is reduced more than 5%, the voltage will drop off rather rapidly with further reductions in speed (see AVR Manual).

SYMPTOM: GENERATOR PRODUCES NO VOLTAGE, OR RESIDUAL VOLTAGE

CAUSE	CHECK AND REMEDY
AVR fuse blown.	Check fuse with ohmmeter. Replace if bad. Refer to AVR manual.
Voltmeter Off.	Check meter selector switch to insure it is not in the Off position.
Defective voltmeter.	Check voltage with separate meter at the generator terminals.
AVR is not getting power.	Measure voltage at input. If no voltage, check for input line-to-line residual voltage.
Loss of residual magnetism.	Flash the field. See "Restoring Residual Magnetism" on page 9 of the SERVICE section.

AVR protective circuit is operating.	Consult AVR manual.
AVR inoperative.	Adjust or replace AVR. Refer to AVR manual.
Open in stator windings.	Check for continuity in the windings. Return to factory or take to service shop if open.
Defective diodes.	Check rectifier assembly (page 9). Replace if defective.
Broken or shorted exciter or main rotor leads.	Test and repair or replace.
Defective exciter windings.	Inspect for damaged or burned exciter or main rotor. Check resistance with Kelvin bridge. Megger for short to core. Return to factory or take to service shop to effect repairs.

SYMPTOM: GENERATOR PRODUCES LOW VOLTAGE, NO LOAD

CAUSE	CHECK AND REMEDY
Faulty metering.	Check voltage with separate meter at generator terminals.
Low Speed.	Check driver for proper speed. Adjust as necessary. Check sheave ratio if belt driven.
Incorrect generator lead connections.	Verify generator connection. See drawings supplied with the unit or appropriate connection diagram in this manual.
Defective connections.	Inspect all wiring for grounds, open circuits, short circuits, or loose/dirty connections.
AVR adjustments.	Adjust AVR per AVR manual. Check exciter field voltage.
Faulty diodes.	Check rectifier assembly (page 9). Replace if defective.
Faulty main rotor.	Check main rotor pole windings. If winding appears to bulge mid-way down body of pole, refer to service shop, or return to factory for service.

SYMPTOM: GENERATOR PRODUCES LOW VOLTAGE WHEN LOAD APPLIED

CAUSE	CHECK AND REMEDY
Driver speed droop, or belt slip.	Check driver. If belt driven, check belt tension. Check "corner frequency" on AVR. Under frequency voltage roll-off may be activated.
Excessive load.	Reduce load. The load on each leg should be as evenly balanced as possible, and it should not exceed rated current on any leg.
Line voltage drop.	If voltage is proper at generator terminals, but low at load terminals, increase external lead size. This is especially true if external leads are long.
Low load power factor.	Reduce lagging power factor load. Some AC motors draw approximately the same current regardless of load. Do not use motors of larger capacity than is necessary to carry the load.

SYMPTOM: GENERATOR PRODUCES FLUCTUATING VOLTAGE (May be indicated by light flicker)

CAUSE	CHECK AND REMEDY
Irregular engine speed.	Check engine for malfunction, or load for fluctuation
AVR stability.	Adjust AVR stability. Refer to AVR manual.
Loose terminal or load connections.	Make better connection both mechanically and electrically.
Defective bearing causing uneven air gap.	Replace worn bearing. Check bearing bore in the bearing bracket for wear. Replace as necessary.

SYMPTOM: GENERATOR PRODUCES HIGH VOLTAGE

CAUSE	CHECK AND REMEDY
Faulty metering.	Check voltage with separate meter at generator terminals.
Excessive speed.	Check engine for malfunction. If belt driven, check sheave ratio.
Incorrect connections.	Verify generator connections. Refer to drawings supplied with unit or with drawings in this manual.
Incorrect AVR sensing.	Consult AVR manual.
AVR adjustments.	Adjust AVR (consult AVR manual).
Defective AVR.	Replace AVR.

SYMPTOM: GENERATOR IS OVERHEATING

CAUSE	CHECK AND REMEDY
Generator is overloaded.	Reduce load. Check with ammeter and compare with nameplate rating.
Clogged ventilating screens.	Clean air passages.
High ambient temperature or altitude.	Improve ventilation, or reduce load.
Insufficient circulation of cooling air.	Provide cross-ventilation.
Dry bearing.	Replace bearing.

SYMPTOM: GENERATOR PRODUCES MECHANICAL NOISE

CAUSE	CHECK AND REMEDY
Defective bearing.	Replace bearing.
Loose or misaligned coupling.	Tighten or realign.
Belt slap or loose guards.	Check belt tensioning. Check belt guard fasteners.

SYMPTOM: GENERATOR PRODUCES SHOCK WHEN TOUCHED

CAUSE	CHECK AND REMEDY
Static charge.	Ground generator frame.
Grounded armature or field coil.	Take to service shop or return to factory for repair.





IMPORTANT INFORMATION



Please Read Carefully

This document is not intended to provide operational instructions. Appropriate Marathon Electric instructions provided with the generator and precautions attached to the generator should be read carefully prior to installation, operations and/or maintenance of the equipment. Injury to personnel or generator failure may be caused by improper installation, maintenance or operation.

The following  and  information is supplied for your protection and to provide you with many years of trouble free and safe operation of your Marathon Electric generator.

WARNING

- Buyer shall be solely responsible for determining the adequacy of the product for any and all uses to which Buyer shall apply the product. The application by Buyer shall not be subject to any implied warranty of fitness for a particular purpose.
- For safety, Buyer or User should provide protective guards over all shaft extensions and any moving apparatus mounted thereon. The User is responsible for checking all applicable safety codes in his area and providing suitable guards. Failure to do so may result in bodily injury and/or damage to equipment.
- Hot oil can cause severe burns. Use extreme care when removing lubrication plugs.
- Disconnect power and lock out drive equipment before working on a generator.
- Always keep hands and clothing away from moving parts.
- The lifting eyes on the generator are not to be used to lift the entire generator set. Only the generator may be safely lifted by the lifting eyes. Do not use the conduit box for lifting or support of the generator.
- Install and ground the generator per local and national codes.
- Discharge all capacitors before servicing the generator.
- Misapplication of a generator in a hazardous environment can cause fire or an explosion and result in serious injury.
- Never attempt to measure the temperature rise of a generator by touch. Temperature rise must be measured by thermometer, resistance, imbedded detector or thermocouple.
- Operation of a generator at higher than its nameplate ratings may result in fire, damage to equipment or serious injury to personnel.
- Do not apply any force to the generator fan when rotating the generator rotor.
- Generators should not be operated faster than their rated speed.

CAUTION

- Mounting bolts should be routinely checked to ensure that the unit is firmly anchored for proper operation.
- Consult qualified personnel with questions. All electrical repairs must be performed by trained and qualified personnel only.
- For inverter applications, follow the inverter manufacturer's installation guidelines.
- Make sure the generator is properly secured and aligned before operation.
- When installing the generator, insure that loose parts or tools do not fall inside the generator.
- When connecting the generator, be sure to follow the correct wiring diagram for the desired voltage. Insure that the voltage regulator is connected per the wiring diagram.

RESALE OF GOODS

In the event of the resale of any of the goods, in whatever form, Resellers/Buyers will include the following language in a conspicuous place and in a conspicuous manner in a written agreement covering such sale:

The manufacturer makes no warranty or representations, express or implied, by operation of law or otherwise, as to the merchantability or fitness for a particular purpose of the goods sold hereunder. Buyer acknowledges that it alone has determined that the goods purchased hereunder will suitably meet the requirements of their intended use. In no event will the manufacturer be liable for consequential, incidental or other damages. Even if the repair or replacement remedy shall be deemed to have failed of its essential purpose under Section 2-719 of the Uniform Commercial Code, the manufacturer shall have no liability to Buyer for consequential damages.

Resellers/Buyers agree to also include this entire document including the cautions and warnings above in a conspicuous place and in a conspicuous manner in writing to instruct users on the safe usage of the product.

This information should be read together with all other printed information supplied by Marathon Electric.

For more information contact: Marathon Electric, Subsidiary of Regal-Beloit Corporation, 100 E. Randolph St., Wausau, WI 54401
Phone: 715-675-3311 or Fax: 715-675-8026

Marathon Electric Mfg. Corp.

P.O. Box 8003

Wausau, WI 54402-8003 USA

Phone: 715.675.3359

Fax: 715.675.8026

www.marathonelectric.com

Printed in USA

GPN016 05/06 (5538J/500/5-06/FS/BH)

