



DCA36SPX

WhisperWatt™ Generator

WhisperWatt™ 36kW

Prime Rating: 36 kW (36 kVA)

Standby Rating: 40 kW (40 kVA)

60 Hertz

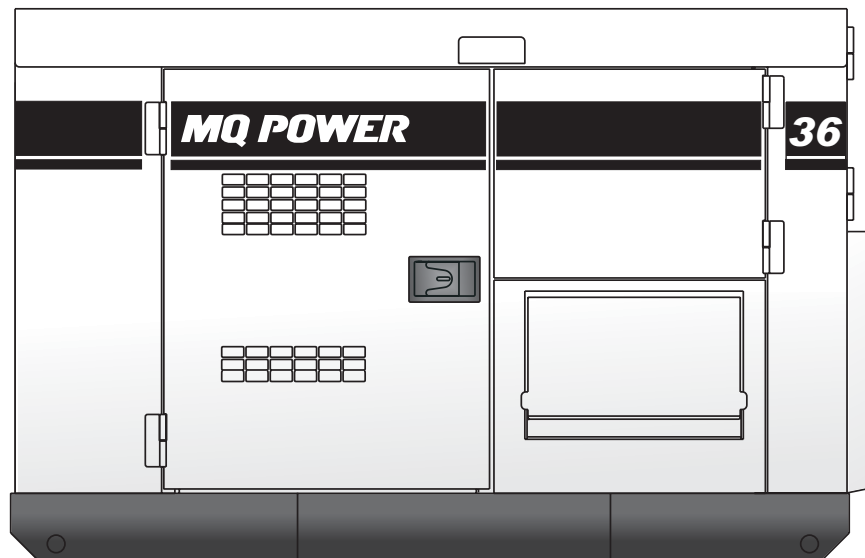

Standard Features

- **Heavy duty, 4-cycle, diesel engine** provides maximum reliability.
- **Brushless alternator** reduces service and maintenance requirements and meets temperature rise standards for Class H insulation systems.
- **Open delta alternator design** provides virtually unlimited excitation for maximum motor starting capability.
- **Automatic voltage regulator (AVR)** provides precise regulation.
- **Full load acceptance** of standby nameplate rating in one step (NFPA 110, para 5-13.2.6).
- **Sound attenuated, weather resistant, steel housing** provides operation at 65 dB(A) at 23 feet. Fully lockable enclosure allows safe unattended operation.
- **Internal fuel tank** with direct reading fuel gauges are standard.
- **Seven-stage powder coat paint** provides durability and weather protection.
- **Fuel/water separator** removes condensation from fuel for extended engine life. Panel mounted alarm light included.
- **Complete engine analog instrumentation** includes DC ammeter, oil pressure gauge, water temp. gauge, fuel level gauge, tachometer/hour meter, and emergency shutdown monitors.
- **Electronic Governor Control (Crystal Sync)** maintains frequency to within $\pm 0.25\%$ from no load to full load.
- **Complete generator analog instrumentation** includes voltage regulator control, ammeter phase selector switch, AC voltmeter, AC ammeter, frequency meter, panel light, and circuit breaker.
- **Automatic safety shutdown system** monitors the water temperature, engine oil pressure, overspeed and overcrank. Warning lights indicate abnormal conditions.
- **Automatic start/stop control** automatically starts the generator set during a commercial power failure when used in conjunction with a transfer switch.
- **Complete power panel.** Fully covered; single phase terminals and single phase receptacles allow fast and convenient hookup for most applications including temporary power boxes, tools and lighting equipment. All are NEMA standard.
- **EPA emissions certified** - Interim Tier 4 emissions compliant.



DCA36SPX

WhisperWatt™ Generator

Specifications

Generator Specifications

Design	Revolving field, self-ventilated drip-proof, single bearing
No. of Poles	4-pole
Excitation	Brushless with AVR
Standby Output	40 kW (40 kVA)
Prime Output	36 kW (36 kVA)
Generator RPM	1800
Voltage — 1Ø	120/240
Voltage Regulation (No load to full load)	±0.5%
Power Factor	1.0
Frequency	60 Hz
Frequency Regulation: No Load to Full Load	Isochronous under varying loads from no load to 100% rated load
Frequency Regulation: Steady State	±0.25% of mean value for constant loads from no load to full load
Insulation	Class H
Sound Level dB(A) Full load at 23 feet	65

Engine Specifications

Make / Model	Isuzu / BB-4JJ1T
Emissions	EPA Interim Tier 4 Certified
Starting System	Electric
Design	4-cycle, water cooled, direct injection, turbocharged
Displacement	183 in ³ (2999 cc)
No. cylinders	4
Bore x Stroke (mm)	95.4 x 104.9
Gross Engine Power Output	67.1 hp (50 kW)
BMEP	136 psi (940 kPa)
Piston Speed	1237 ft./min. (6.29 m/s)
Compression Ratio	17.5 : 1
Engine Speed	1800 rpm
Overspeed Limit	2100 rpm
Oil Capacity	3.96 gal (15.0 L)
Battery	12V 72Ah x 1

Fuel System

Maximum Fuel Flow (per hour)	16 gallons (61 liters)	
Maximum Inlet Restriction (Hg)	5.9 in. (150 mm)	
Fuel Tank Capacity	26.5 gallons (100.0 liters)	
Fuel Consumption	gph	lph
At full load	2.8	10.6
At 3/4 load	2.1	8.0
At 1/2 load	1.5	5.6
At 1/4 load	0.9	3.4

Cooling System

Fan Load	0.94 HP (0.7 KW)
Coolant Capacity (with radiator)	2.96 gallons (11.2 liters)
Coolant Flow Rate (per minute)	15.4 gallons (58.5 liters)
Heat Rejection to Coolant (per minute)	1640 Btu (1.73 MJ)
Maximum Coolant Friction Head	6.1 psi (42 kPa)
Maximum Coolant Static Head	21 feet (6.4 meters)
Ambient Temperature Rating	104°F (40°C)

Air

Combustion Air	99 cfm (2.8 m ³ /min)
Maximum Air Cleaner Restriction	25 in. H ₂ O (6.2 kPa)
Alternator Cooling Air	526 cfm (14.9 m ³ /min)
Radiator Cooling Air	2330 cfm (66.0 m ³ /min)

Exhaust System

Gas Flow (full load)	233 cfm (6.6 m ³ /min)
Gas Temperature	896°F (480°C)
Maximum Back Pressure	53.2 in. H ₂ O (13.3 kPa)

Amperage

Rated Voltage	Maximum Amps
1Ø 120 Volt	150 x 2
1Ø 240 Volt	150
Main Line Circuit Breaker Rating	150 Amps

Warranty*

Isuzu Engine

12 months from date of purchase with unlimited hours or 24 months from date of purchase with 2000 hours (whichever occurs first).

Generator

24 months from date of purchase or 2000 hours (whichever occurs first).

Trailer

12 months excluding normal wear items.

*Refer to the express written, one-year limited warranty sheet for additional information.

Generator is not intended for use in enclosed areas or where free flow of air is restricted.
Backfeed to a utility system can cause electrocution and/or property damage.
Do not connect to any building's electrical system except through an approved device.

Specifications are subject to change without notice.



DCA36SPX WhisperWatt™ Generator

MQ POWER DECIBEL LEVELS



Our soundproof housing allows substantially lower operating noise levels than competitive design. WhisperWatts™ are at home on construction sites, in residential neighborhoods, and at hospitals — just about anywhere.

- 90 — Subway / truck traffic
- 80 — Average city traffic
- 70 — Inside car at 60 mph
— WhisperWatt™ at 23 feet
- 60 — Air conditioner at 20 feet
- 50 — Normal conversation

65.0
DECIBELS

Generator Output Panel

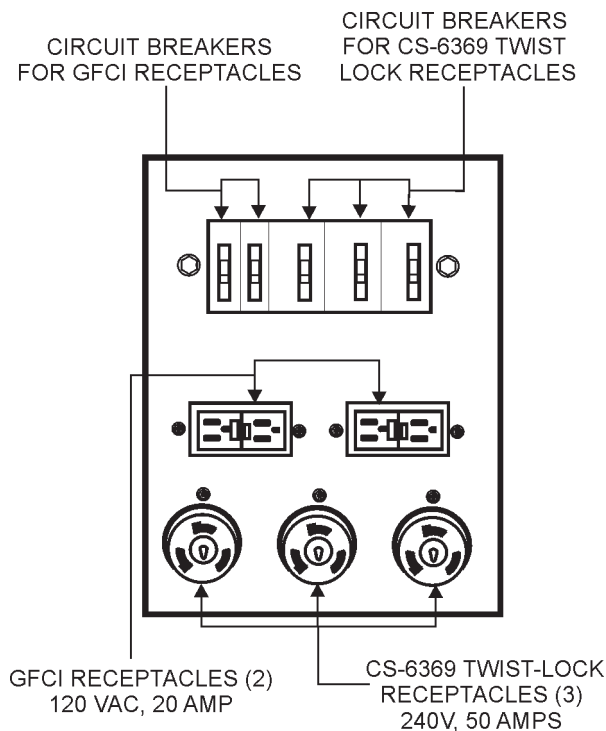

Optional Generator Features

- Battery Charger** — provides fully automatic and self-adjusting charging to the generator's battery system.
- Special Batteries** — long life batteries provide extra engine cranking power.
- Low Coolant Level Shutdown** — provides protection from critically low coolant levels. Includes control panel warning light.
- Jacket Water Heater** — for easy starting in cold weather climates.
- Spring Isolators** — provides extra vibration protection for standby applications.
- Trailer Mounted Package** — highway legal trailer with electric or hydraulic brakes with tandem axle configuration.

Optional Control Features

- Emergency Stop Switch.**
- Audible Alarm** — alerts operator of abnormal conditions.

Optional Fuel Cell Features

- Trailer fuel tank** — a second fuel cell located in the trailer allows for extended run time.
- Sub-base fuel cells (double wall)** — Additional fuel cell for extended runtime operation. Contains a leak sensor, low fuel level switch, and a secondary containment tank. UL142 listed.
 - 12 hours of minimum run time.
 - 24 hours of minimum run time.

Optional Distribution Devices

- Cam-Lock connectors.**
- Pin & Sleeve Connectors.**
- AC Output Cable.**



DCA36SPX

WhisperWatt™ Generator

Dimensions

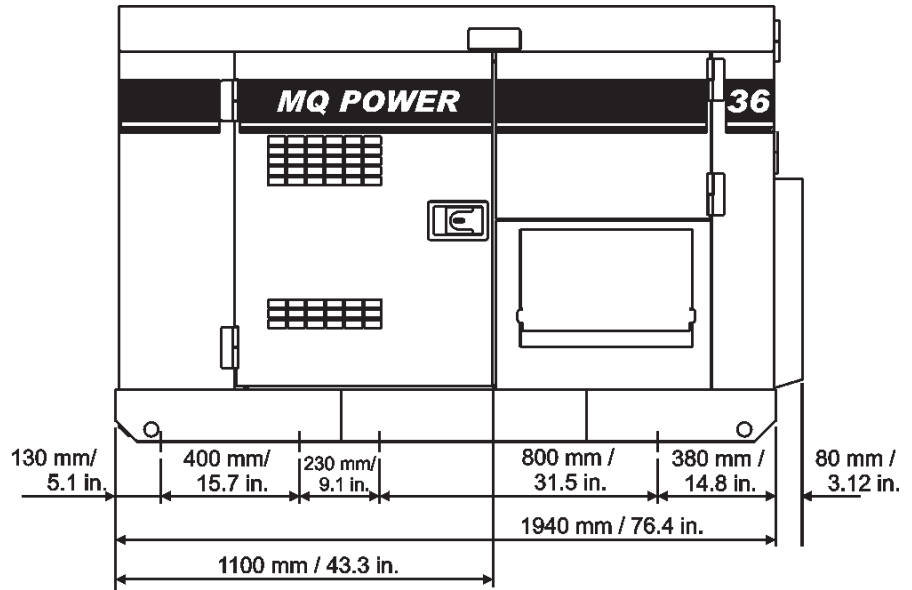
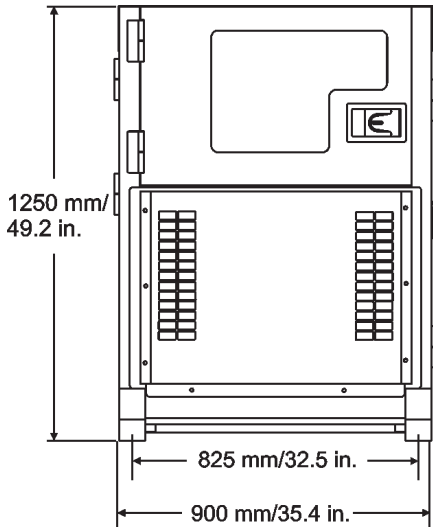

Weight

Dry Weight	2,315 lbs. (1,050 kg)
Wet Weight	2,557 lbs. (1,160 kg)
Max. Lifting Point Capacity	5,150 lbs. (2,335 kg)

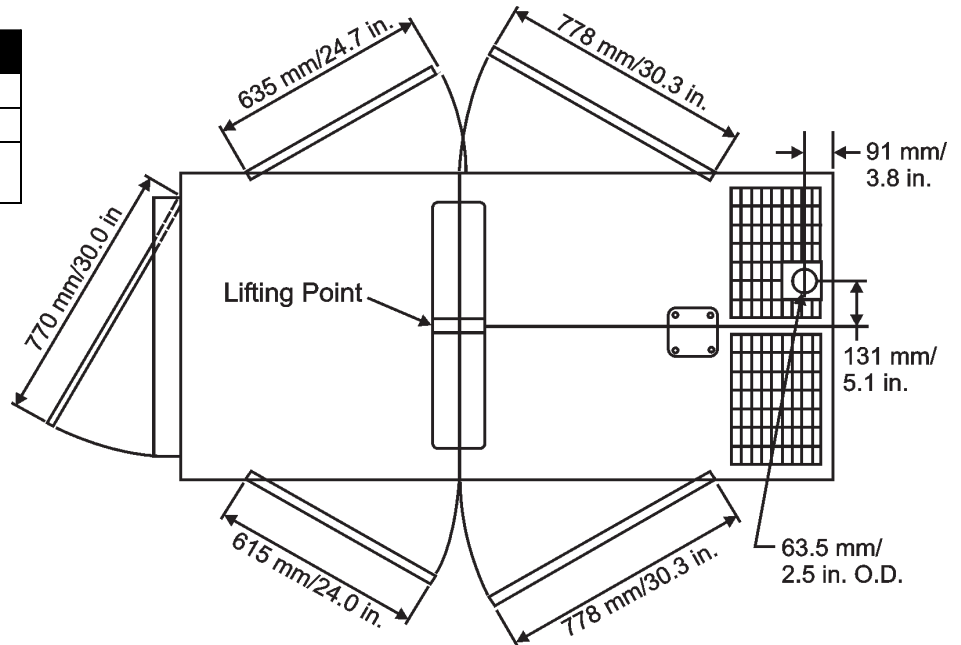

Units manufactured by Denyo Corp.

Your MQ Power dealer is:

Hardy Diesels & Equipment Inc.
15749 Lyons Valley Rd.
Jamul, CA 91935
800-341-7027
www.HardyDiesel.com

