



# DCA600SSV

## WhisperWatt™ Generator

### WhisperWatt™ 600

Prime Rating: 480 kW (600 kVA)

Standby Rating: 528 kW (660 kVA)

60 Hertz

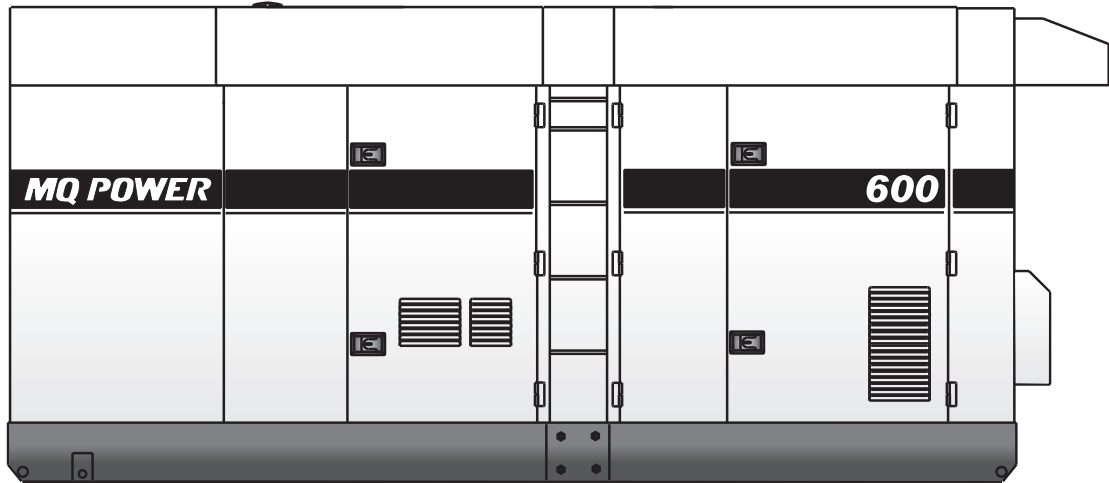

#### Standard Features

- **Heavy duty, 4-cycle direct injection, turbocharged, air-to-air intercooled diesel engine** provides maximum reliability.
- **Brushless alternator** reduces service and maintenance requirements and meets temperature rise standards for Class F insulation systems.
- **Open delta alternator design** provides virtually unlimited excitation for maximum motor starting capability.
- **Automatic voltage regulator (AVR)** provides precise regulation.
- **Electronic governor system** maintains frequency to  $\pm 0.25\%$ .
- **Full load acceptance** of standby nameplate rating in one step (NFPA 110, para 5-13.2.6).
- **Sound attenuated, weather resistant, steel housing** provides operation at 74 dB(A) at 23 feet. Fully lockable enclosure allows safe unattended operation.
- **Internal fuel tank** with direct reading fuel gauges are standard.
- **E-Coat primer** with polyurethane enamel finish coat.
- **Fuel/water separators** remove condensation from fuel for extended engine life.
- **Simultaneous single and three phase power.**
- **Battery switch**
- **Complete engine analog instrumentation** includes DC ammeter, oil pressure gauge, water temp. gauge, tachometer/hour meter, preheat indicator, manual engine speed control, emergency shutdown monitors, and emergency stop button.
- **Complete generator analog instrumentation** includes voltage regulator control, ammeter phase selector switch, voltmeter phase selector switch, AC voltmeter, AC ammeter, frequency meter, panel light, and circuit breaker.
- **Automatic safety shutdown system** monitors the water temperature, engine oil pressure, overspeed, and overcrank. Warning lights indicate abnormal conditions.
- **Auto start/stop control** allows generator to start automatically in the event of a commercial power failure.
- **Complete power panel.** Fully covered; three-phase terminals and single phase receptacles allow fast and convenient hookup for most applications including temporary power boxes, tools and lighting equipment. All are NEMA standard.
- **Voltage change over board** allows easy to change voltages as your applications require. 240/480 Buss Bar.
- **Low coolant level shutdown system** provides protection from critically low coolant levels. Includes control panel warning light.
- **Emergency stop switch**
- **EPA emissions certified** - Tier 2 emissions compliant.



# DCA600SSV

## WhisperWatt™ Generator

### Generator Specifications

Design	Revolving field, self-ventilated, Drip-proof, single bearing
No. of Poles	4-pole
Excitation	Brushless with AVR
Standby Output	528 KW (660 KVA)
Prime Output	480 KW (600 KVA)
Generator RPM	1800
Voltage — 3Ø	208, 220, 240, 416, 440, 480V Reconnectable
Voltage — 1Ø	120, 127, 139, 240, 254, 277V Adjustable
Armature Connection	Star with neutral
Voltage Regulation (No load to full load)	±0.5%
Power Factor	0.8
Frequency	60 Hz
Frequency Regulation: No Load to Full Load	Isochronous under varying loads from no load to 100% rated load
Frequency Regulation: Steady State	±0.25% of mean value for constant loads from no load to full load
Insulation	Class F
Sound Level dB(A) Full load at 23 feet	74

### Engine Specifications

Make / Model	Volvo/TAD1642GE
Emissions	EPA Tier 2 Certified
Starting System	Electric
Design	4-cycle, watercooled, direct injection turbocharged, air to air intercooled
Displacement	16120 cc
No. cylinders	6
Bore x Stroke (mm)	144 x 165
Gross Engine Power Output	810 bhp (604 kWm)
BMEP	362 psi (2498 kPa)
Piston Speed	1949 ft./min. (9.9 m/s)
Compression Ratio	16.5 : 1
Engine Speed	1800 rpm
Overspeed Limit	2070 rpm
Oil capacity gallons (liters)	12.7 (48.0)
Battery	200Ah x 2 (24V System)

### Fuel System

Recommended Fuel	ASTM-D975-No.1 or No. 2-D	
Maximum Fuel Flow (per hour)	53 gal. (200 L)	
Maximum Inlet Restriction (Hg)	2.59 in (75 mm)	
Fuel Tank Capacity	129 gal. (490 L)	
<b>Fuel Consumption</b>	<b>gph</b>	<b>lph</b>
full load	33.1	125.2
75% load	24.2	91.7
50% load	17.3	65.4
25% load	10.5	39.6

### Cooling System

Fan Load	25.5 hp (19 kW)
Coolant Capacity (with radiator)	24.6 gal. (93.0 L)
Coolant Flow Rate	122 gal. (462 L)
Heat Rejection to Coolant (per minute)	14104 Btu (14.9 MJ)
Heat Rejection to Engine (per minute)	1365 Btu (1.44 MJ)
Maximum Coolant Friction Head	9.0 psi (60 kPa)
Maximum Coolant Static Head	34 ft (10 m)
Ambient Temperature Rating	104°F (40°C)

### Air

Combustion Air	1646 cfm (46.6 m³/min)
Maximum Air Cleaner Restriction	20.1 in. H²O (5 kPa)
Alternator Cooling Air	3023 cfm (84.6 m³/min)
Radiator Cooling Air	19224 cfm (544 m³/min)

### Exhaust System

Gas Flow (full load)	4153 cfm (117.6 m³/min)
Gas Temperature	954°F (512°C)
Maximum Back Pressure	40.2 in H²O (10 kPa)

### Amperage

Rated Voltage	Maximum Amps
1Ø 120 Volt	1333.3 Amps (4 wire)
1Ø 240 Volt	666.7 Amps (4 wire)
3Ø 240 Volt	1443.4 Amps
3Ø 480 Volt	721.7 Amps
Main Line Circuit Breaker Rating	1600 Amps
Over Current Relay Trip Set Point	720 Amps

### Warranty\*

#### Volvo Engine

24 months from date of purchase and unlimited hours.

#### Generator

24 months from date of purchase or 2000 hours (whichever occurs first).

#### Trailer

12 months excluding normal wear items.

\*Refer to the express written, one-year limited warranty sheet for additional information.

Generator is not intended for use in enclosed areas or where free flow of air is restricted. Backfeed to a utility system can cause electrocution and/or property damage. Do not connect to any building's electrical system except through an approved device.

**Specifications are subject to change without notice.**



# DCA600SSV WhisperWatt™ Generator

## MQ POWER DECIBEL LEVELS

Our soundproof housing allows substantially lower operating noise levels than competitive designs. WhisperWatts are at home on construction sites, in residential neighborhoods, and at hospitals — just about anywhere.

- 90 — Subway / truck traffic
- 80 — Average city traffic
- 74.0 — **WhisperWatt at 23 feet**
- 70 — Inside car at 60 mph
- 60 — Air conditioner at 20 feet
- 50 — Normal conversation



## Generator Output Panels

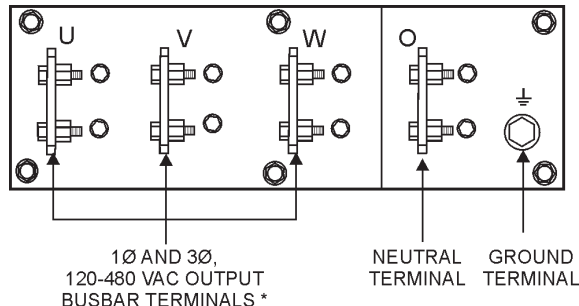
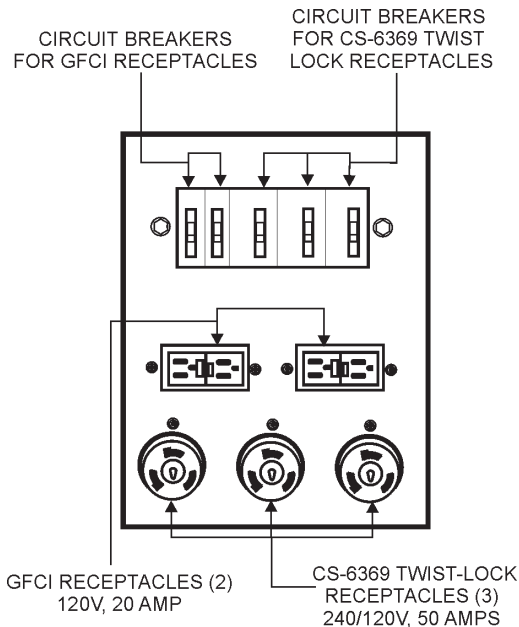

## Optional Generator Features

- Battery charger** — provides fully automatic and self-adjusting charging to the generator's battery system.
- Jacket water heater** — for easy starting in cold weather climates.
- Special batteries** — long life batteries provide extra engine cranking power.
- Spring Isolators** — provides extra vibration protection for standby applications.
- Trailer mounted package** — highway legal, drop deck, semi-trailer with air brakes. Extra capacity fuel tanks are also available.

## Optional Control Features

- Audible alarm** — alerts operator of abnormal conditions.

## Optional Fuel Cell Features

- Trailer fuel tank** — a second fuel cell located in the trailer allows for extended run time.
- Subbase fuel cells (double wall)** — Additional fuel cell for extended runtime operation. Contains a leak sensor, low fuel level switch, and a secondary containment tank. UL142 listed.
  - 12 hours of minimum run time.
  - 24 hours of minimum run time.

## Optional Output Connections

- Pin and Sleeve connectors** — provides industry standard connectors for all voltage requirements.
- Output cable** — available in any custom length and size configuration.



# DCA600SSV

## WhisperWatt™ Generator

### Dimensions

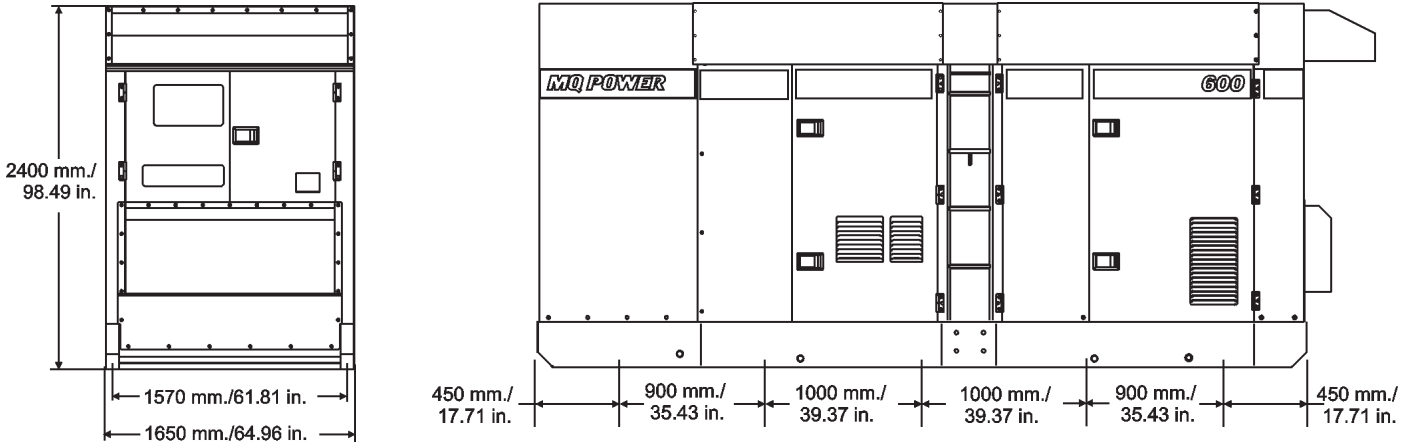

### Weight

Dry Weight	16373 lbs (7425 kg)
Wet Weight	17662 lbs (8010 kg)
Max. Lifting Point Capacity	25000 lbs (11340 kg)

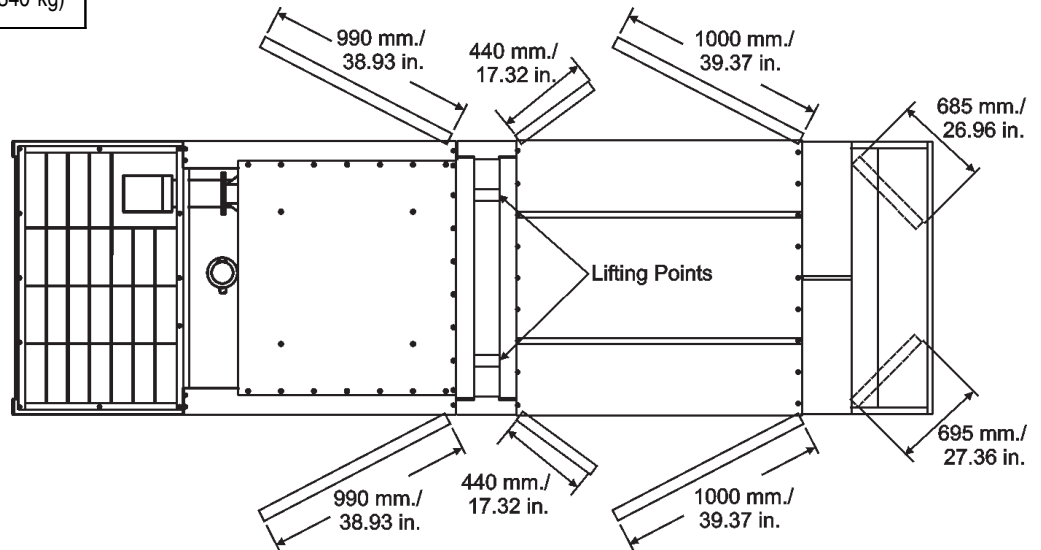

Units manufactured by Denyo Corp.

Your MQ Power dealer is:

Hardy Diesels & Equipment Inc.  
 15749 Lyons Valley Rd.  
 Jamul, CA 91935  
 800-341-7027  
 www.HardyDiesel.com

