



DCA70SSJU4F

Generator

WhisperWatt™

Prime Rating — 56 kW (70 kVA)

Standby Rating — 62 kW (77 kVA)

3-Phase, 50/60 Hertz, 0.8 PF

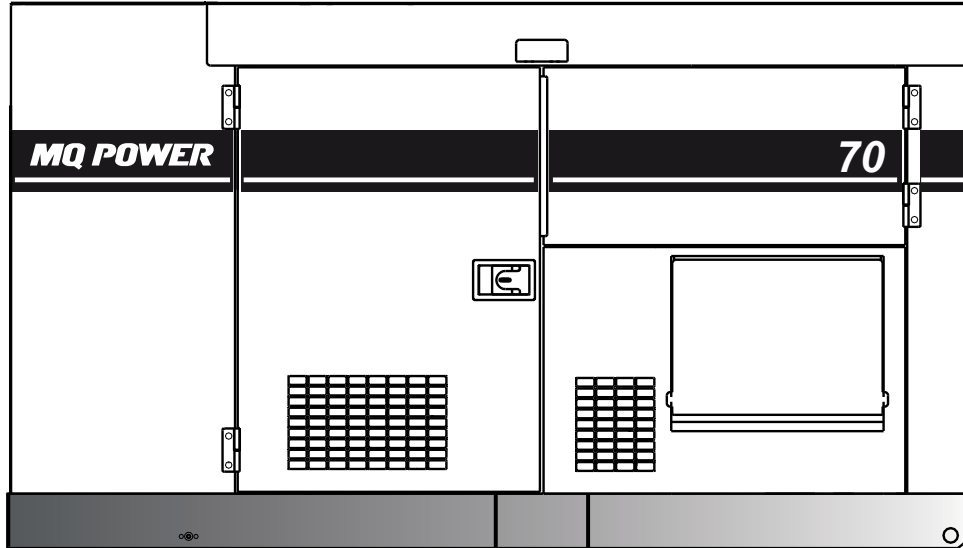

STANDARD FEATURES

- Heavy duty, 4-cycle, direct injection, turbocharged, charge air cooled, 1000W block heater, diesel engine provides maximum reliability.
- EPA emissions certified - Tier 4 Final emissions compliant.
- Microprocessor engine control system maintains frequency to $\pm 0.25\%$.
- Full load acceptance of standby nameplate rating in a single step.
- Fuel/water separator removes condensation from fuel for extended engine life. Panel-mounted alarm light included.
- Sound attenuated, weather resistant, steel housing provides operation at 66 dB(A) at 23 feet. Fully lockable enclosure allows safe unattended operation.
- E-coat and powder coat paint provide durability and weather protection.
- Internal fuel tank with direct reading fuel gauge.
- Brushless alternator reduces service and maintenance requirements and meets temperature rise standards for Class H insulation systems.
 - Open delta alternator design provides virtually unlimited excitation for maximum motor starting capability.
 - Automatic voltage regulator (AVR) provides precise regulation.
- Fully covered power panel. Three-phase terminals and single phase receptacles allow fast and convenient hookup for most applications including temporary power boxes, tools and lighting equipment. All are NEMA standard.
- ECU845 microprocessor-based digital generator controller.
 - Remote 2-wire start/stop control.
 - High visibility LCD display with heated screen and alphanumeric readout.
 - Operational temperature range of -40° to 85° C.
 - AC monitoring along with fuel and DEF level indicators.
- Digital engine gauges including oil pressure, water temperature, battery volts, engine speed, engine load, fuel level and DEF level.
- Analog generator instrumentation including AC ammeter, AC voltmeter, frequency meter, ammeter phase selector switch, voltmeter phase selector switch, and voltage regulator adjustment potentiometer.
- Automatic safety shutdown system monitors the water temperature, low coolant, engine oil pressure, overspeed, and overcrank. Warning lights indicate abnormal conditions.
- Voltage selector switch offers the operator a wide range of voltages that are manually selectable. Fine tuning of the output voltage can be accomplished by adjusting the voltage regulator control knob to obtain the desired voltage.
- Dual frequency capability allows for operation at 50 Hz or 60 Hz.



DCA70SSJU4F

Generator

SPECIFICATIONS

Generator Specifications		
Design	Revolving field, self-ventilated Drip-proof, single bearing	
Armature Connection	Star with Neutral	Zig Zag
Phase	3	Single
Standby Output	62 KW (77 KVA)	44 KW
Prime Output	56 KW (70 KVA)	40 KW
3Ø Voltage (L-L/L-N) Voltage Selector Switch at 3Ø 240/139	208Y/120, 220Y/127, 240Y/139	N/A
3Ø Voltage (L-L/L-N) Voltage Selector Switch at 3Ø 480/277	416Y/240, 440Y/254, 480Y/277	N/A
1Ø Voltage (L-L/L-N) (Voltage Selector Switch at 1Ø 240/120)	N/A	240/120
Power Factor	0.8	1.0
Voltage Regulation (No load to full load)	±0.5%	
Generator RPM	1800	
Frequency	50/60 Hz	
Winding Pitch	2/3	
No. of Poles	4	
Excitation	Brushless with AVR	
Frequency Regulation: No Load to Full Load	Isochronous under varying loads from no load to 100% rated load	
Frequency Regulation: Steady State	±0.25% of mean value for constant loads from no load to full load.	
Insulation	Class H	
Sound Level dB(A) Full load at 23 feet	66	

Engine Specifications	
Make / Model	John Deere/4045HFG04
Emissions	EPA Tier 4 Final Certified
Starting System	Electric
Design	4-cycle, water cooled, direct injection, turbocharged, charge air cooled, EGR, DOC and SCR
Displacement	274.6 in ³ (4500 cc)
No. cylinders	4
Bore x Stroke (mm)	106 x 127
Gross Engine Power Output	107 hp (80 kW)
BMEP	155 psi (1070 kPa)
Piston Speed	1500 ft./min. (7.62 m/s)
Compression Ratio	17.0:1
Engine Speed	1800 rpm
Overspeed Limit	2070 rpm
Oil Capacity	3.88 gallons (14.7 liters)
Battery	12V 75Ah x 1

Fuel System		
Recommended Fuel	ASTM-D975-No.1 & No.2-D*	
Maximum Fuel Flow (per hour)	13.2 gallons (50 liters)	
Maximum Inlet Restriction (Hg)	5.9 in. (150 mm)	
Fuel Tank Capacity	19.8 gallons (75 liters)	
Fuel Consumption	gph	lph
At full load	4.6	17.5
At 3/4 load	3.6	13.8
At 1/2 load	2.7	10.4
At 1/4 load	2.0	7.6
DEF Tank Capacity	7.98 gallons (30 liters)	

* - Use ultra-low sulfur diesel fuel.

Cooling System	
Fan Load	7.5 hp (5.6 kW)
Coolant Capacity (with radiator)	6.3 gallons (23.7 liters)
Coolant Flow Rate (per minute)	57.6 gallons (218 liters)
Heat Rejection to Coolant (per minute)	2903 Btu (3.06 MJ)
Maximum Coolant Friction Head	5.8 psi (40 kPa)
Maximum Coolant Static Head	78.7 feet (24.1 meter)
Ambient Temperature Rating	104°F (40°C)

Air	
Combustion Air	208 cfm (5.9 m ³ /min)
Maximum Air Cleaner Restriction	25 in. H ₂ O (6.3 kPa)
Alternator Cooling Air	526 cfm (14.9 m ³ /min)
Radiator Cooling Air	5250 cfm (149 m ³ /min)

Exhaust System	
Gas Flow (full load)	445 cfm (12.6 m ³ /min)
Gas Temperature	752°F (400°C)
Maximum Back Pressure	46 in. H ₂ O (11.5 kPa)

Amperage	
Rated Voltage	Maximum Amps
1Ø 120 Volt	168 Amps x 2 (Zigzag)
1Ø 240 Volt	168 Amps (Zigzag)
3Ø 208 Volt	168 Amps
3Ø 240 Volt	168 Amps
3Ø 480 Volt	84 Amps
Main Line Circuit Breaker Rating	168 Amps
Over Current Relay Trip Set Point 480V Mode Only	84 Amps

WARRANTY*

John Deere Engine

12 months from date of purchase with unlimited hours or 24 months prior to the accumulation of 2000 hours (whichever occurs first).

Generator

24 months from date of purchase or 2000 hours (whichever occurs first).

Trailer

12 months excluding normal wear items.

*Refer to the express written, one-year limited warranty sheet for additional information.

NOTICE

Specifications sheet is subject to change and is not intended for use in installation design.



DCA70SSJU4F Generator

MQ POWER DECIBEL LEVELS

Our soundproof housing allows substantially lower operating noise levels than competitive designs. WhisperWatts are at home on construction sites, in residential neighborhoods, and at hospitals — just about anywhere.

- 90 — Subway / truck traffic
- 80 — Average city traffic
- 70 — Inside car at 60 mph
- 60 — Air conditioner at 20 feet
- 50 — Normal conversation



GENERATOR OUTPUT PANEL

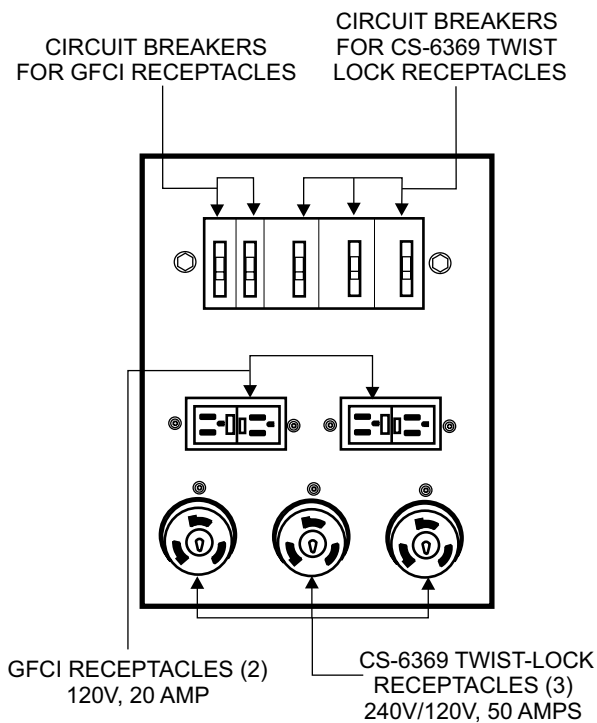

OPTIONAL GENERATOR FEATURES

- **PowerBalance™** — designed to assist generators when operating under low temperature and/or low load conditions to insure peak performance.
- **Battery Charger** — provides fully automatic and self-adjusting charging to the generator's battery system.
- **Crankcase Vent Blanket with Heating Element** — insures proper crankcase ventilation in freezing conditions. (Unit comes standard with a non-heated crankcase blanket)
- **Trailer Mounted Package** — meets National Highway Traffic Safety Administration (NHTSA) regulations. Trailer is equipped with electronic or surge brakes with double axle configuration.

OPTIONAL CONTROL FEATURES

- **Emergency Stop Switch** — when manually activated, shuts down generator in the event of an emergency.
- **Audible Alarm** — alerts operator of abnormal conditions.

OPTIONAL FUEL CELL FEATURES

- **Sub-base fuel cells (double wall)** — additional fuel cell for extended runtime operation. Contains a leak sensor, low fuel level switch, and a secondary containment tank. UL142 listed.
- 12 hours of minimum run time.
- 24 hours of minimum run time.

OPTIONAL OUTPUT CONNECTIONS

- **Cam-Lok Connectors** — provides quick disconnect alternative to bolt-on connectors.
- **Pin and Sleeve Connectors** — provides industry standard connectors for all voltage requirements.
- **Output Cable** — Available in any custom length and size configuration.



DCA70SSJU4F

Generator

SKID-MOUNT DIMENSIONS

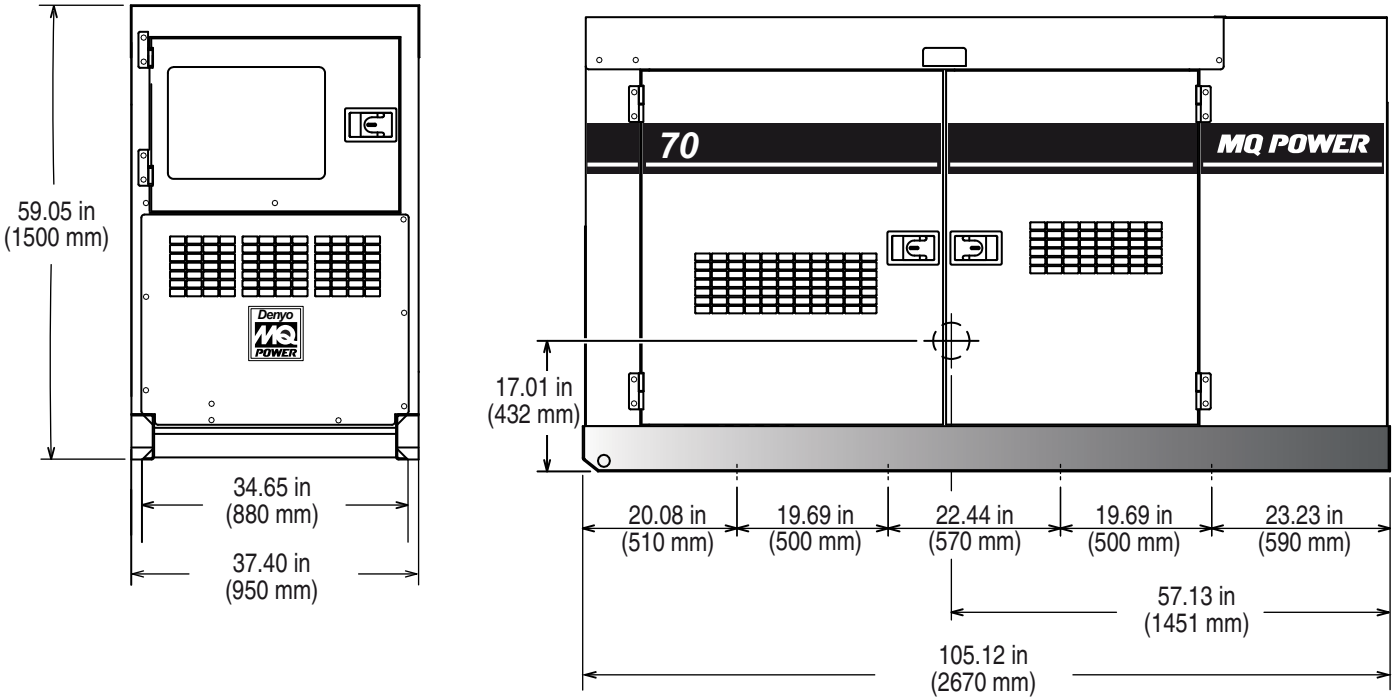

TRAILER-MOUNT DIMENSIONS

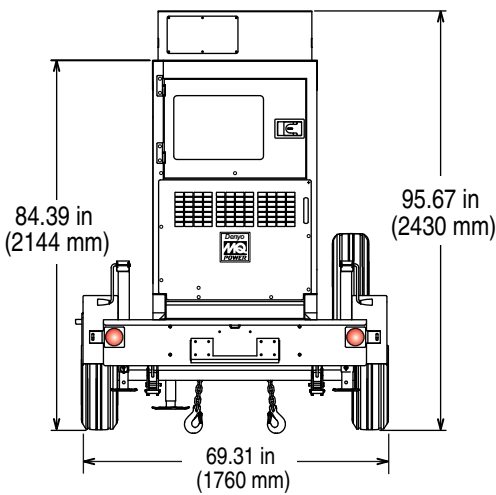

Shown with optional
 TRLR75XF2H,
 PowerBalance™
 Stabilizer Jacks,
 Spare Tire,
 Storage Box,
 Folding Step and
 Grab Handle

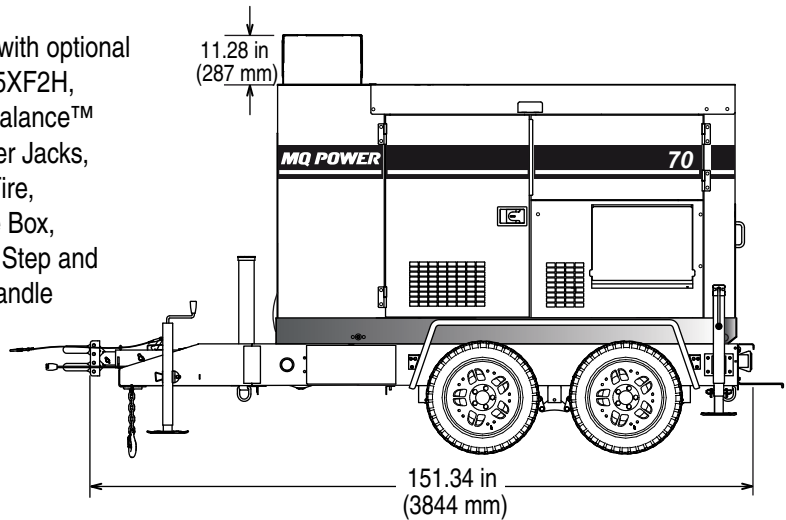

DCA70SSJU4F Weights*

Dry Weight	3,539 lbs. (1,605 kg)
Wet Weight	3,858 lbs. (1,750 kg)
Max. Lifting Point Capacity	6,960 lb. (3,157 kg)

* Weights do not include options.

DCA70SSJU4F and TRLR75XF2 Weights*

Dry Weight (with TRLR75XF2)	4,837 lbs. (2,194 kg)
Wet Weight (with TRLR75XF2)	5,156 lbs. (2,339 kg)

Generator can be placed on MQ Trailer Model TRLR75XF2 (H/E).

NOTICE

Features and Specifications are subject to change without notice.



MULTIQUIP
 POST OFFICE BOX 6254
 CARSON, CA 90749
 310-537-3700 • 800-883-2551
 FAX: 310-604-3831
 E-MAIL: sales@multiquip.com
 WEBSITE: www.multiquip.com